

MY FIRST WRITING

WORKBOOK



Don't worry.
Just write it!

How to Use the Workbook





A. Organizing Ideas for Writing

Unit 5 LESSON 2 Sea Animals

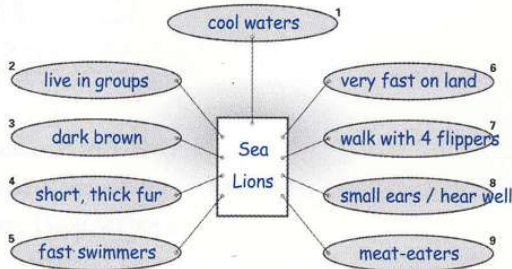
A. Complete the chart.

>> Write words about a sea animal.
Write the animal's name in the box.



Word Bank			
			
Dolphins a sleek body smooth skin a powerful tail flippers a blowhole / head	Octopuses a soft body eight arms a large brain two large eyes change color	Stingrays a flat body a dangerous tail broad fins eyes / top a mouth / underside	Bull Sharks the most dangerous sharks gray / top, white / belly sharp, pointy teeth eat meat smell very well

My First Writing 2

► Idea Web

- Think about the topic.
- Write the subject(s) in the box(es).
- Write verbs and other components in the circles.
- Try to use your own words.
- Go to the specified page in the student book for help.

► Word Bank

- Use the word bank when necessary.
- Try to remember the words that go together.



B. Final Writing

Unit 5 Wild Animals

B. Write your story.

>> Look at the chart on the left. Draw and write your story.

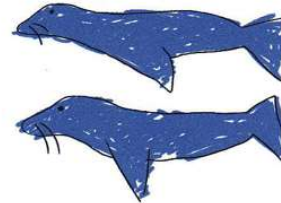

Title **Roaring Sea Lions**

- Sea lions live in cool waters.
- They live in groups.
- They are dark brown.
- They have short, thick fur.
- They are fast swimmers.
- They are very fast on land too.
- They walk with all four flippers.
- They have small ears, but they can hear well.
- They are meat-eaters.

► Picture

- Draw a picture based on your writing.
- You can glue a photo too.

► Passage Writing

- Write the title of your story.
- Go to number 1 in the chart in Part A.
- Write sentence 1 using the words in the box and the circle(s).
- Continue with the rest of the sentences to complete the passage.
- Use pronouns when possible.

MY FIRST WRITING 2

CONTENTS

Part I

UNIT 1 My Family and Friends

Lesson 1	My Family and I	4
Lesson 2	My Mom and Dad	6
Lesson 3	My Relatives	8
Lesson 4	My Friends	10

UNIT 2 My Favorites

Lesson 1	My Favorite Sport	12
Lesson 2	My Favorite Store	14
Lesson 3	My Favorite Park	16
Lesson 4	My Favorite Fruit	18

UNIT 3 Outdoor Activities

Lesson 1	On the School Ground	20
Lesson 2	At the Beach	22
Lesson 3	On the Mountain	24
Lesson 4	Adventures of J & J: The Lost Love	26

My Family and I

Go to page 13
in your student
book for help.



A. Complete the chart.

>> Write words about you and your family.

Write your brother's or sister's name in the box.

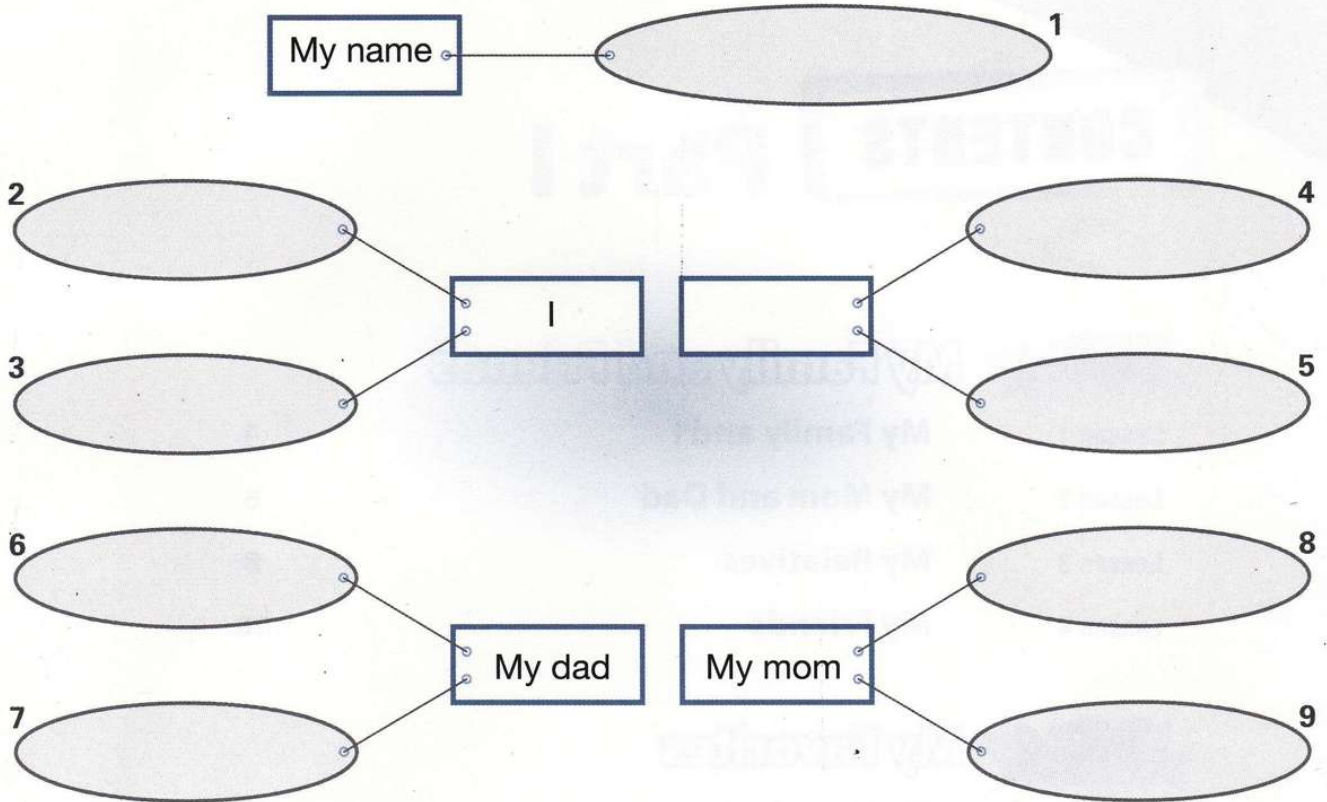

Word Bank

To Teachers: Encourage students to use their own words. When necessary, have them refer to the word bank.



(9) years old



in (second) grade



brother



sister



businessman



homemaker



teacher



dentist



cook



police officer

B. Write your story.

>> Look at the chart on the left. Draw and write your story.

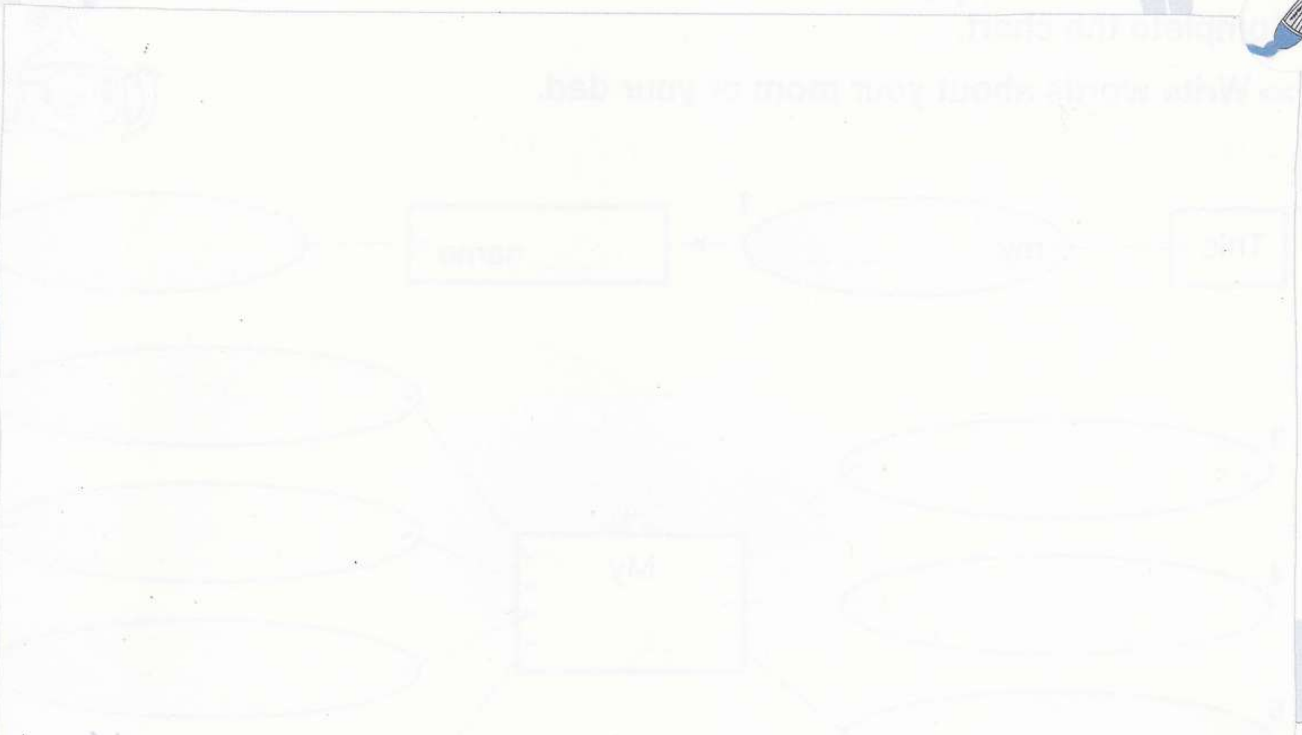

Title _____

- 1 _____
- 2 _____
- 3 _____
- 4 _____
- 5 _____
- 6 _____
- 7 _____
- 8 _____
- 9 _____

My Mom and Dad

Go to page 17
in your student
book for help.



A. Complete the chart.

>> Write words about your mom or your dad.

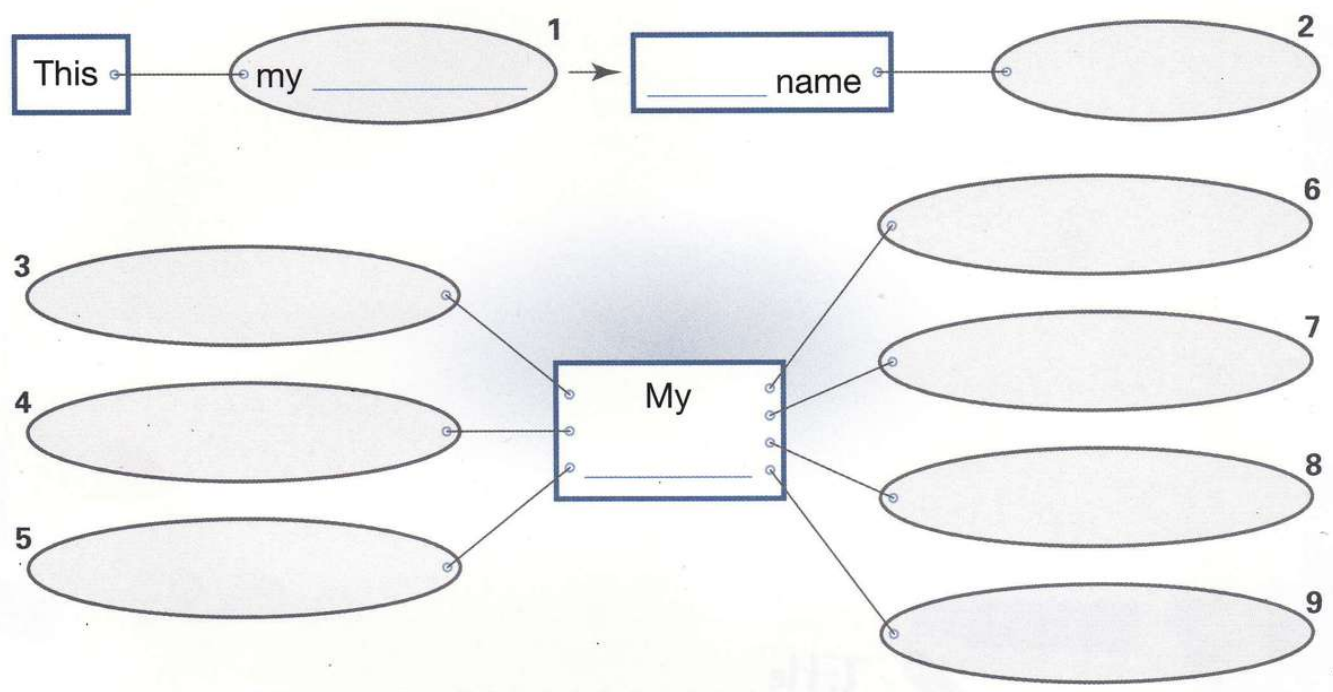

Word Bank

To Teachers: Encourage students to use their own words. When necessary, have them refer to the word bank.

teacher	bank teller	store owner	homemaker	doctor	cook
at a school	at a bank	at a store	at home	at a hospital	at a restaurant
makes snacks	helps me with homework	plays with me	tells me stories		

B. Write your story.

>> Look at the chart on the left. Draw and write your story.



Title _____

- 1 _____
- 2 _____
- 3 _____
- 4 _____
- 5 _____
- 6 _____
- 7 _____
- 8 _____
- 9 _____

My Relatives

Go to page 21
 in your student
 book for help.



A. Complete the chart.

>> Write words about one of your relatives.

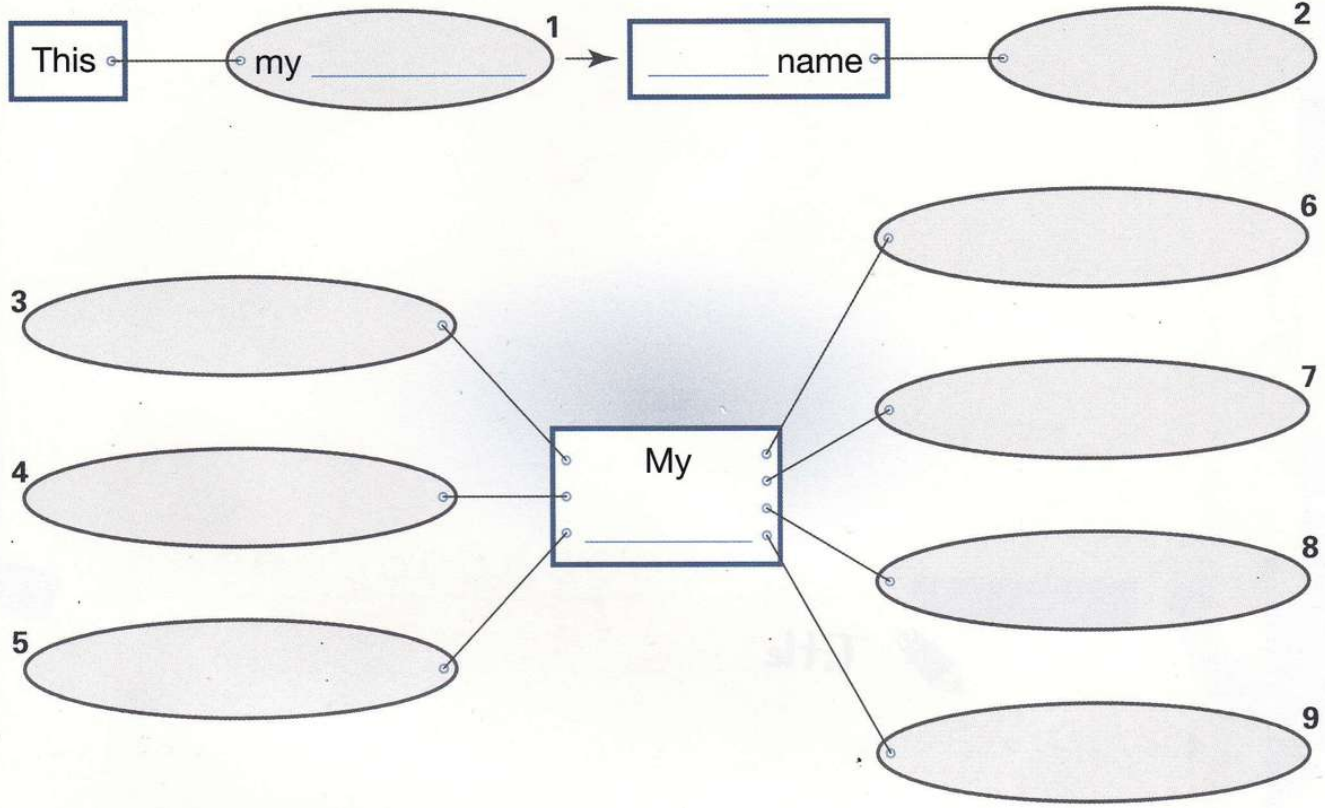

Word Bank

To Teachers: Encourage students to use their own words. When necessary, have them refer to the word bank.

grandma	grandpa	uncle	aunt	cousin			
wonderful	handsome	short	funny	healthy	busy	kind	smart

B. Write your story.

>> Look at the chart on the left. Draw and write your story.



A large rectangular writing area with a spiral binding on the left side. The area is divided into a top section for a drawing and a bottom section for writing. The drawing section contains a faint background illustration of a house with a chimney, a tree, and a fence. The writing section consists of nine horizontal lines, each starting with a number from 1 to 9 on the left side. The lines are dashed, with a solid top line and a solid bottom line, and a dashed middle line. The word "Title" is written in blue cursive on the first line, preceded by a small pencil icon.

My Friends

Go to page 25
in your student
book for help.



A. Complete the chart.

>> Write words about your friends.
Write your friends' names in the boxes.

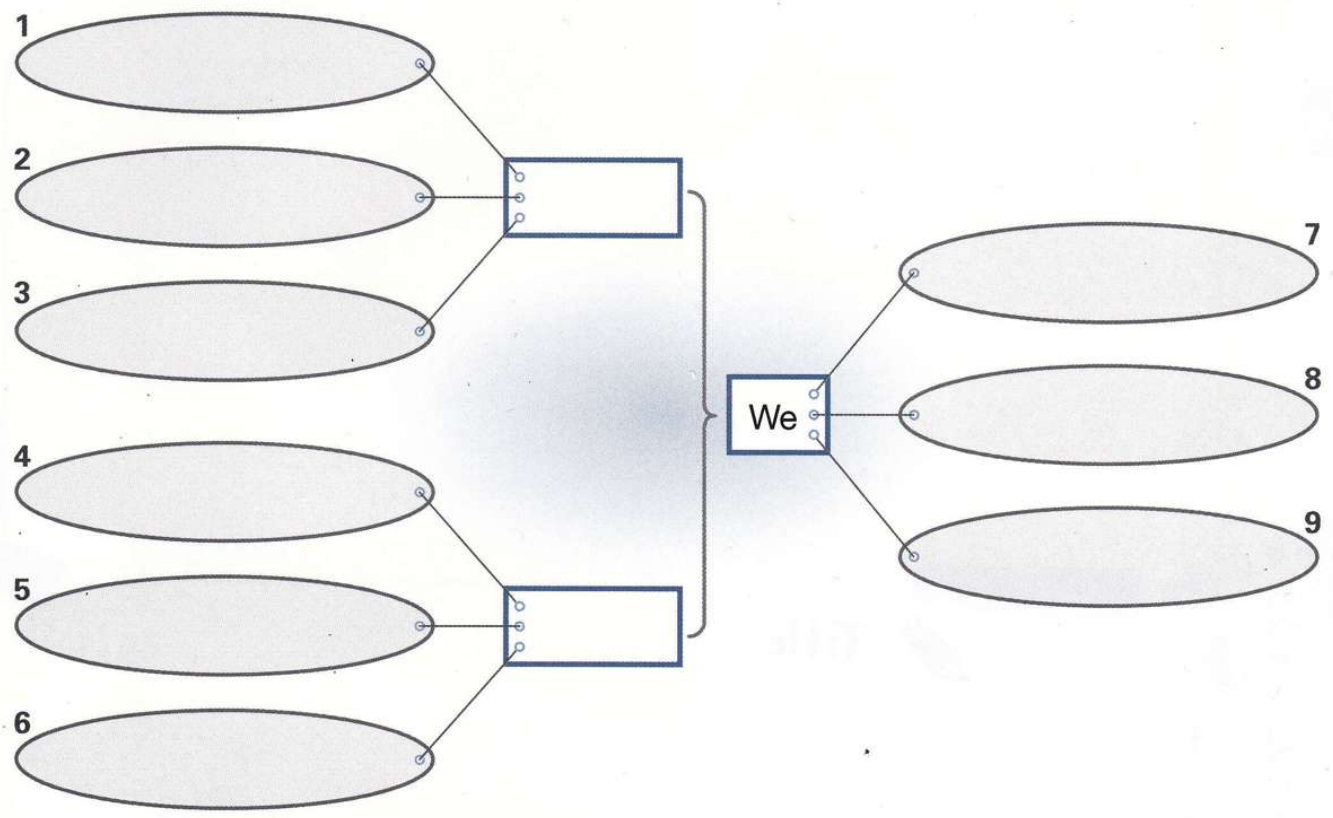

Word Bank

To Teachers: Encourage students to use their own words. When necessary, have them refer to the word bank.

 tall	 pretty	 funny	 smart				
				plays the (guitar / flute / piano / drums)			
							
likes (music / animals / soccer / kittens)				have (long / short / black) hair		best friends	

B. Write your story.

>> Look at the chart on the left. Draw and write your story.



Title _____

- 1 _____
- 2 _____
- 3 _____
- 4 _____
- 5 _____
- 6 _____
- 7 _____
- 8 _____
- 9 _____

My Favorite Sport

Go to page 31
in your student
book for help.



A. Complete the chart.

>> Write words about your favorite sport.
Write the name of the sport in the box.

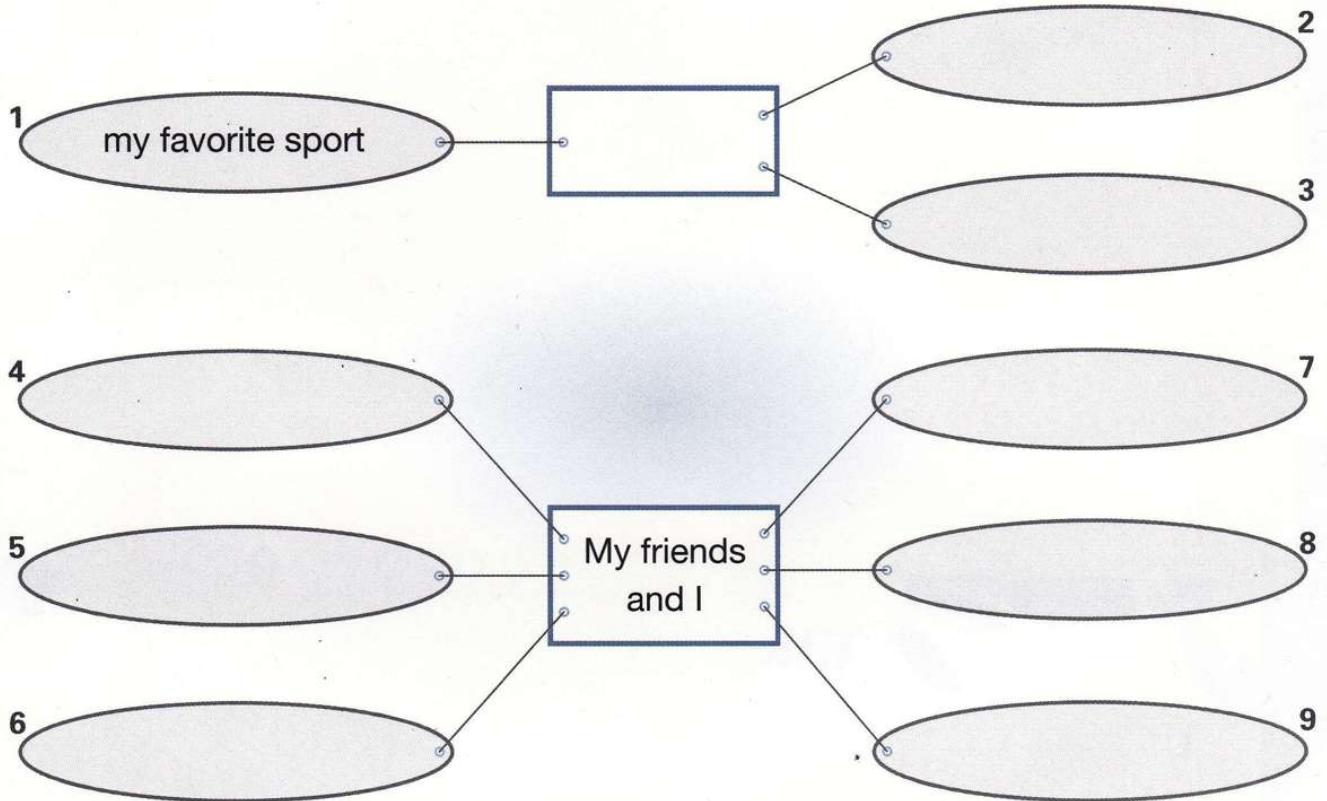

Word Bank

To Teachers: Encourage students to use their own words. When necessary, have them refer to the word bank.

 soccer	 kick	 head	 baseball	 throw	 catch	 hit
 swimming	 swim	 dive	 basketball	 dribble	 pass	 shoot

B. Write your story.

>> Look at the chart on the left. Draw and write your story.



Title

1

2 It

3

4

5 We

6

7

8

9



My Favorite Store

Go to page 35 in your student book for help.



A. Complete the chart.

>> Write words about your favorite store.

There ¹

It ² our favorite store

It ³

4

5

We

My ⁶

My ⁷

My ⁸

I ⁹

Word Bank

To Teachers: Encourage students to use their own words. When necessary, have them refer to the word bank.



• bookstore



1 comic books



2 science books



3 story books



• toy store



1 stuffed animals



2 board games



3 robots



• shoe store



1 sandals



2 sneakers



3 boots



• clothing store



1 shirts



2 skirts



3 pants

B. Write your story.

>> Look at the chart on the left. Draw and write your story.

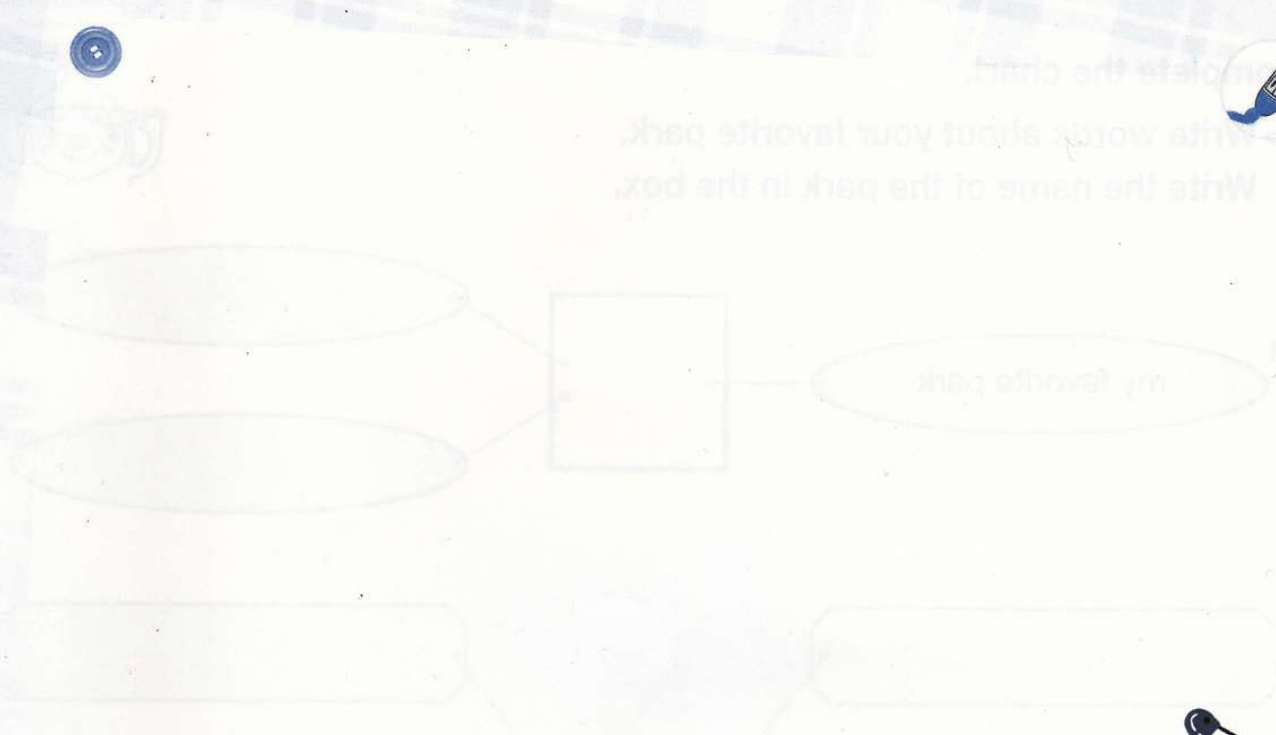

Title _____

1 _____

2 _____

3 _____

4 _____

5 _____

6 _____

7 _____

8 _____

9 _____



My Favorite Park

Go to page 39
 in your student
 book for help.



A. Complete the chart.

>> Write words about your favorite park.
 Write the name of the park in the box.

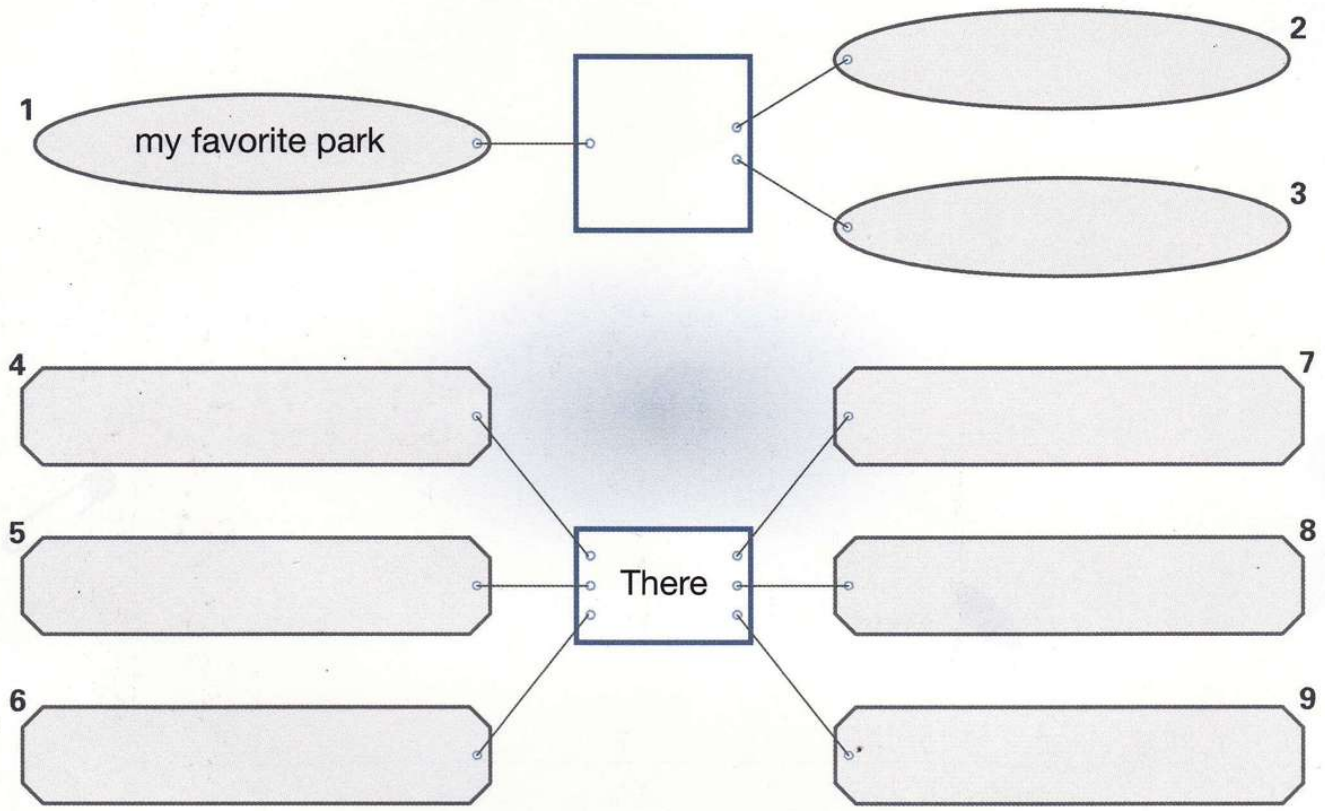

Word Bank

To Teachers: Encourage students to use their own words. When necessary, have them refer to the word bank.



- amusement park
- ① bumper cars
- ② roller coaster
- ③ merry-go-round



- water park
- ① wave pool
- ② hot pool
- ③ water slide



- city park
- ① pond
- ② ducks
- ③ bike trail

B. Write your story.

>> Look at the chart on the left. Draw and write your story.



Title _____

1 _____

2 It _____

3 _____

4 _____

5 _____

6 _____

7 _____

8 _____

9 _____



My Favorite Fruit

Go to page 43
in your student
book for help.



A. Complete the chart.

>> Write words about your favorite fruit.
Write the name of the fruit in the box.

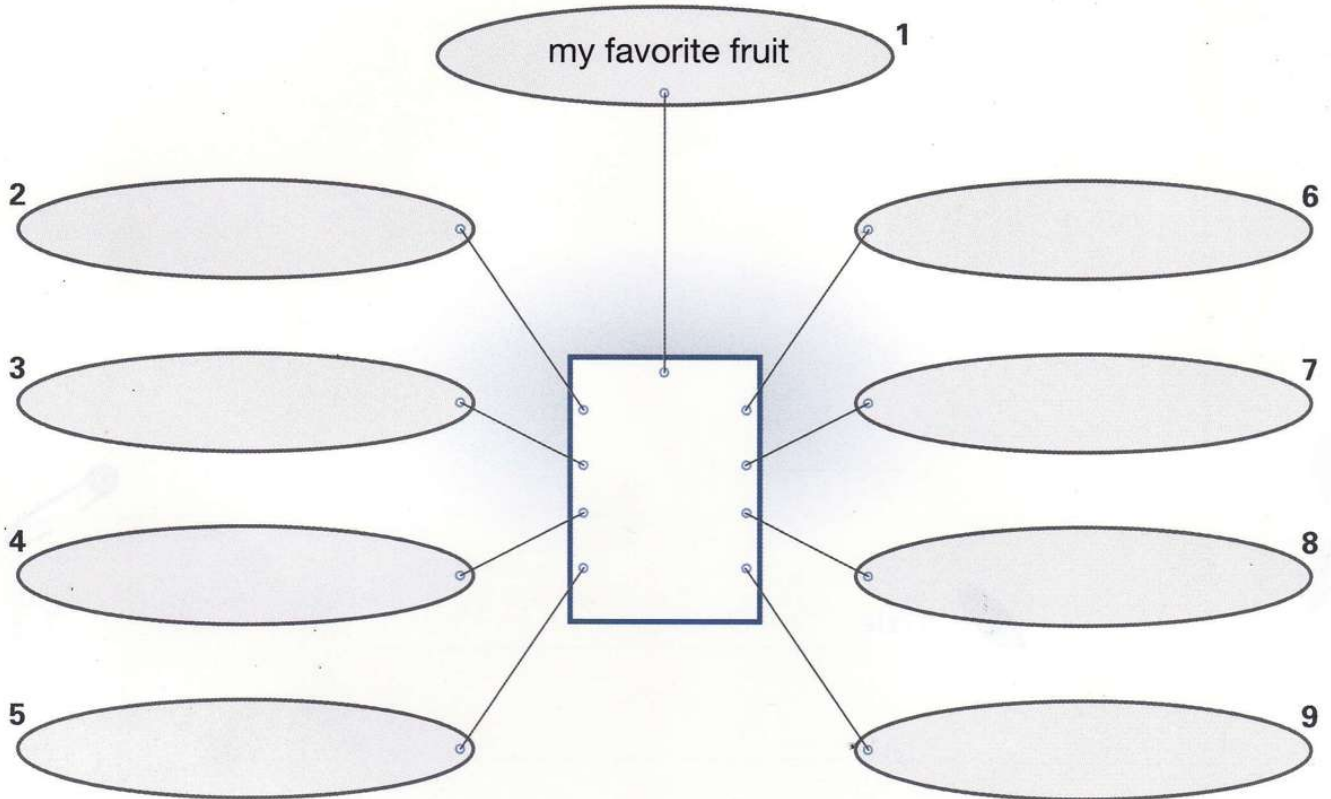

Word Bank

To Teachers: Encourage students to use their own words. When necessary, have them refer to the word bank.



peach



orange



lemon



bananas



strawberries



grapes



seeds



purple



round



oval



long



sour



sweet



fuzzy



soft

B. Write your story.

>> Look at the chart on the left. Draw and write your story.



Title _____

- 1 _____
- 2 _____
- 3 _____
- 4 _____
- 5 _____
- 6 _____
- 7 _____
- 8 _____
- 9 _____



On the School Ground

Go to page 49
in your student
book for help.



A. Complete the chart.

>> Write words about your playtime activity.

Write the names of your friends in the boxes.

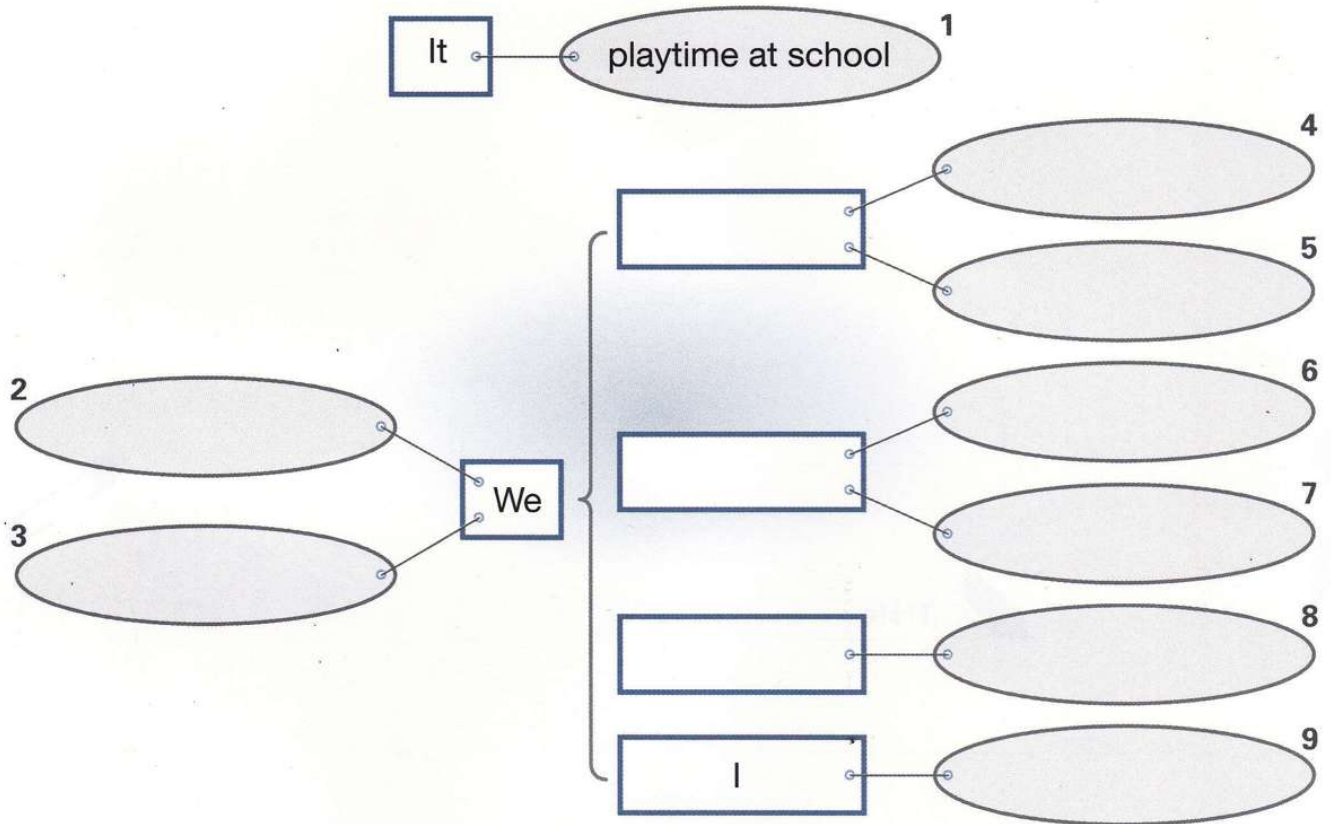

Word Bank

To Teachers: Encourage students to use their own words. When necessary, have them refer to the word bank.



playing hide and seek



counting



hiding



playing tag



chasing



trying to catch



playing badminton



holding



hitting



jumping rope



turning



jumping

B. Write your story in the present continuous tense.

>> Look at the chart on the left. Draw and write your story.



A large rectangular area with a decorative border of small circles along the top edge, intended for drawing a story.



Title _____

Numbered lines for writing the story:

- 1 _____
- 2 _____
- 3 _____
- 4 _____
- 5 _____
- 6 _____
- 7 _____
- 8 _____
- 9 _____

At the Beach

Go to page 53
 in your student
 book for help.



A. Complete the chart.

>> Write words about your family activities at the beach.

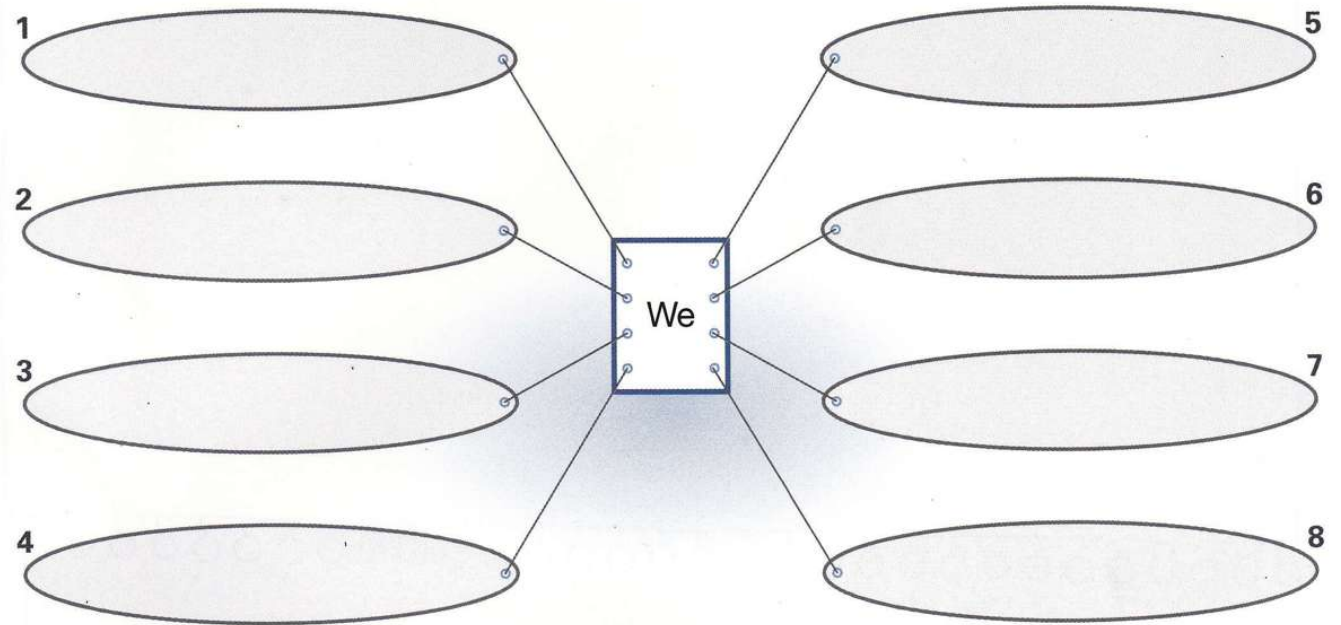

It always _____ at the beach 9

Word Bank

To Teachers: Encourage students to use their own words. When necessary, have them refer to the word bank.

collect shells	go walking	bodysurf	play with a beach ball	eat ice cream	read
build sand castles	catch crabs	surf	get a sun tan	play beach volleyball	fish

B. Write your story.

>> Look at the chart on the left. Draw and write your story.

A large blank area for drawing, framed by a spiral binding on the left and top. A small blue pencil icon is in the top right corner. Faint background illustrations of a giraffe and a house are visible.



Title _____

1

2

3

4

5

6

7

8

9

On the Mountain

Go to page 57
in your student
book for help.



A. Complete the chart.

>> Write words about your family activities on the mountain.

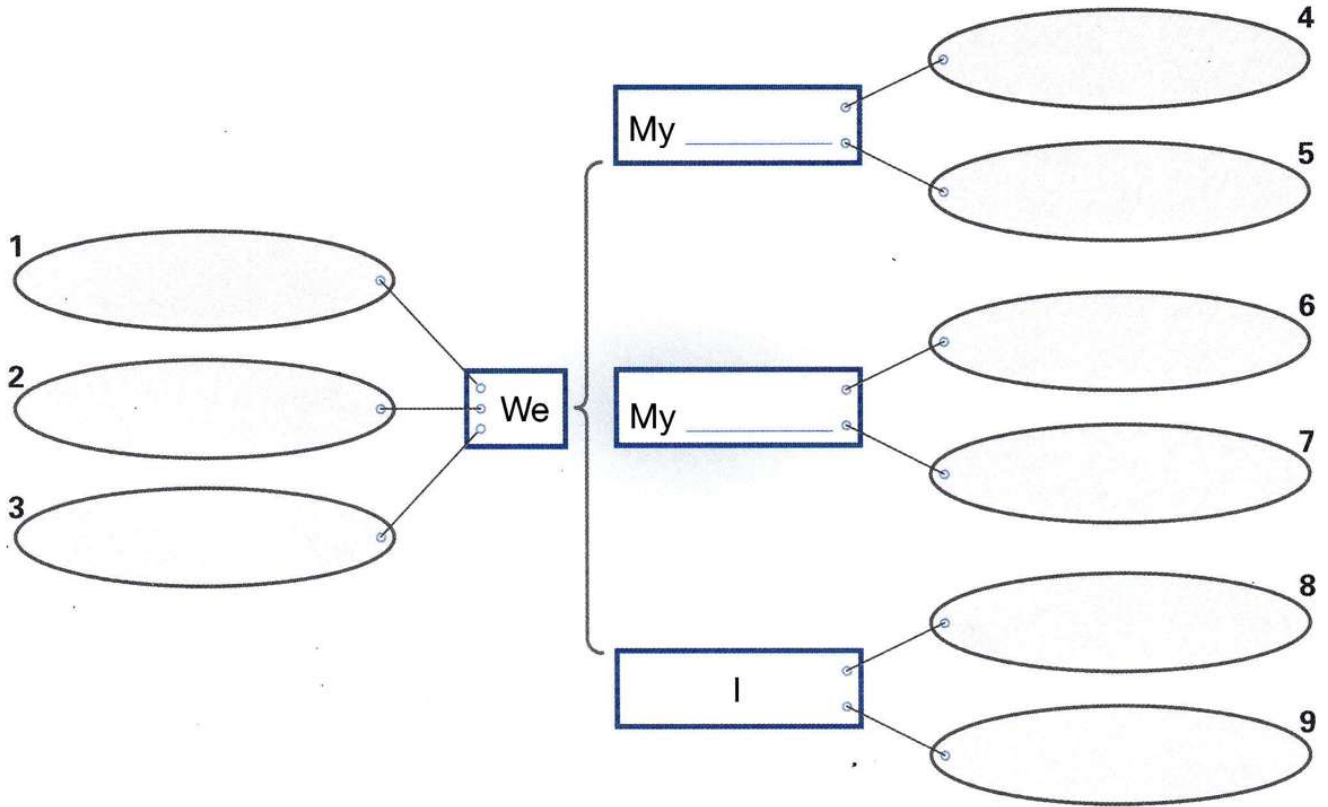

Word Bank

To Teachers: Encourage students to use their own words. When necessary, have them refer to the word bank.



skiing



skis



goggles



poles



cave exploring



lantern



helmet



rope



hiking



cane



sun hat



hiking boots



camping



backpack



tent



sleeping bag

B. Write your story in the present continuous tense.

>> Look at the chart on the left. Draw and write your story.

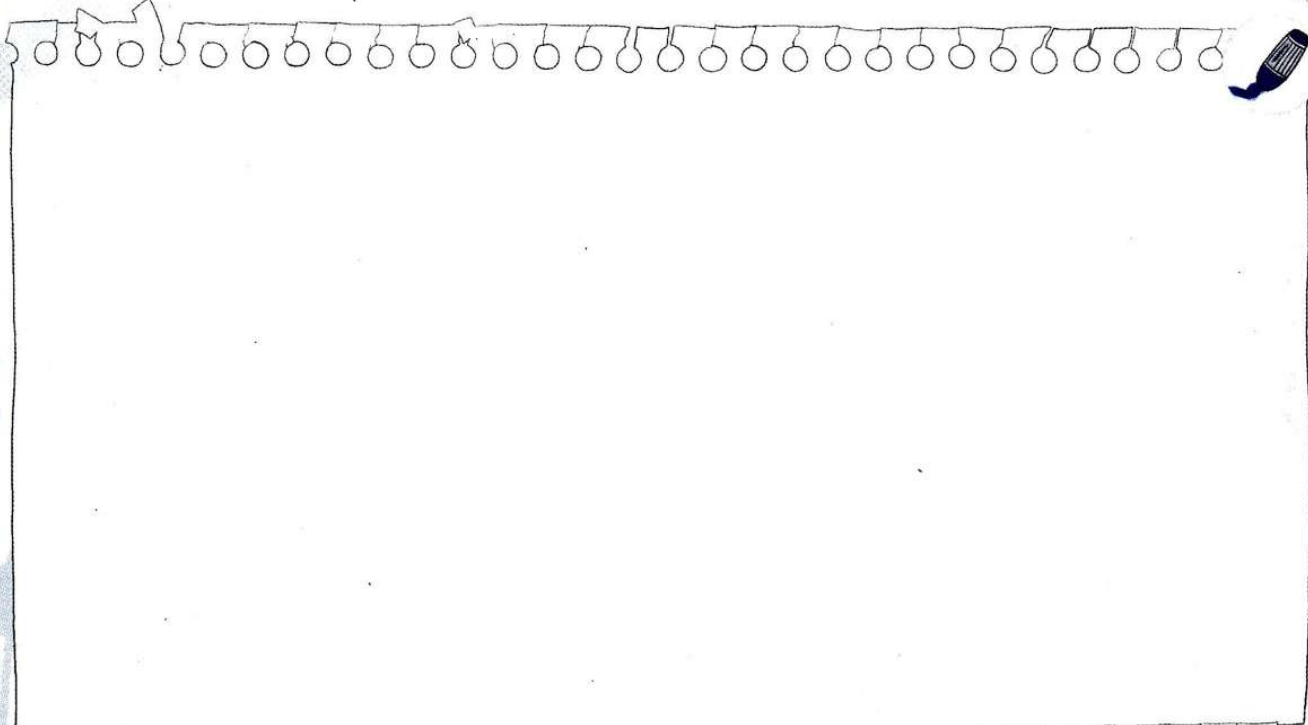

 **Title** _____

1 _____

2 _____

3 _____

4 _____

5 _____

6 _____

7 _____

8 _____

9 _____



Adventures of J & J

- The Lost Love -

A. Choose and complete the chart.

go has (x3) is looking lives put on see

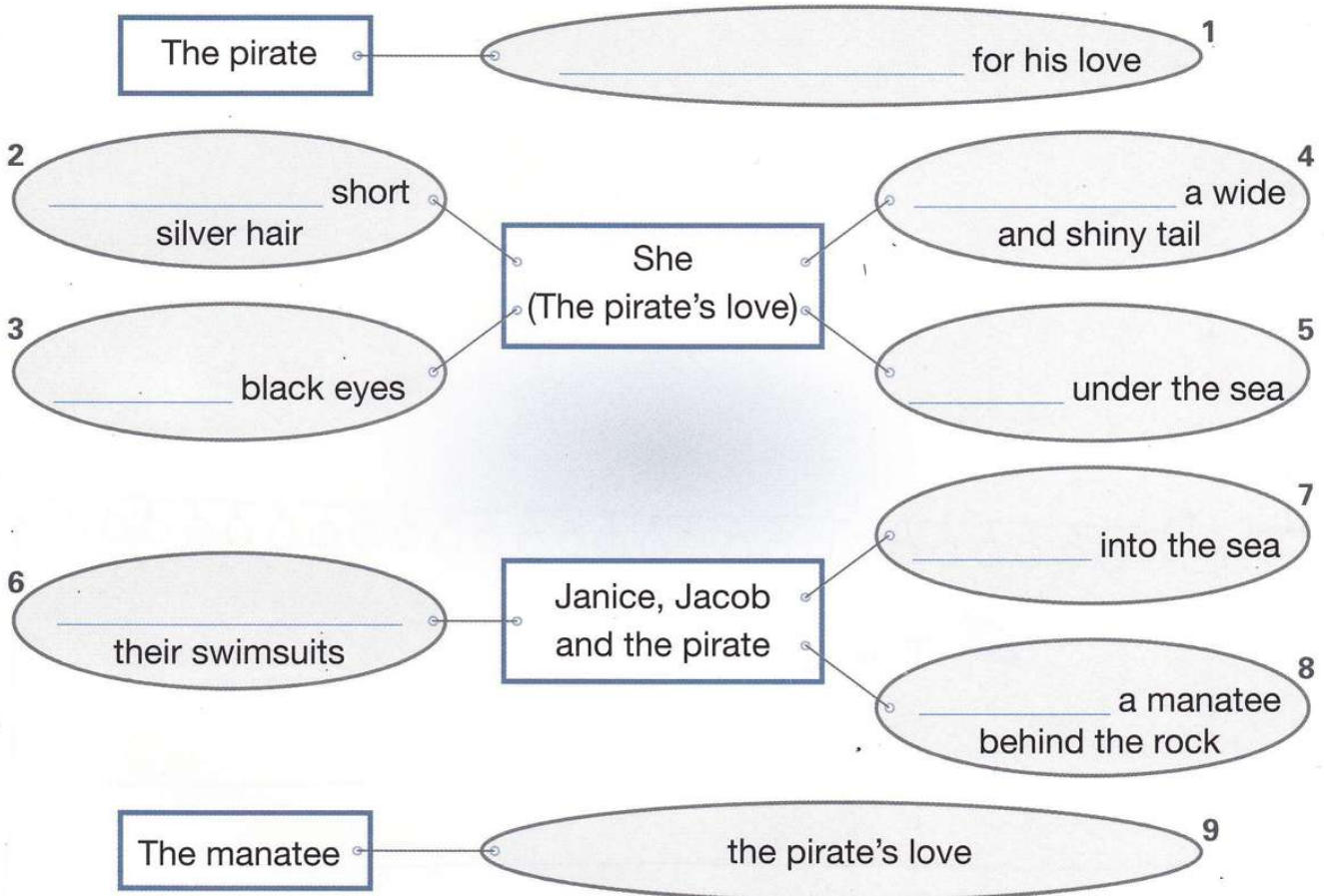

B. Write the summary of the comic. Use a Be-verb when necessary.

>> Look at the chart on the left. Draw and write the summary.

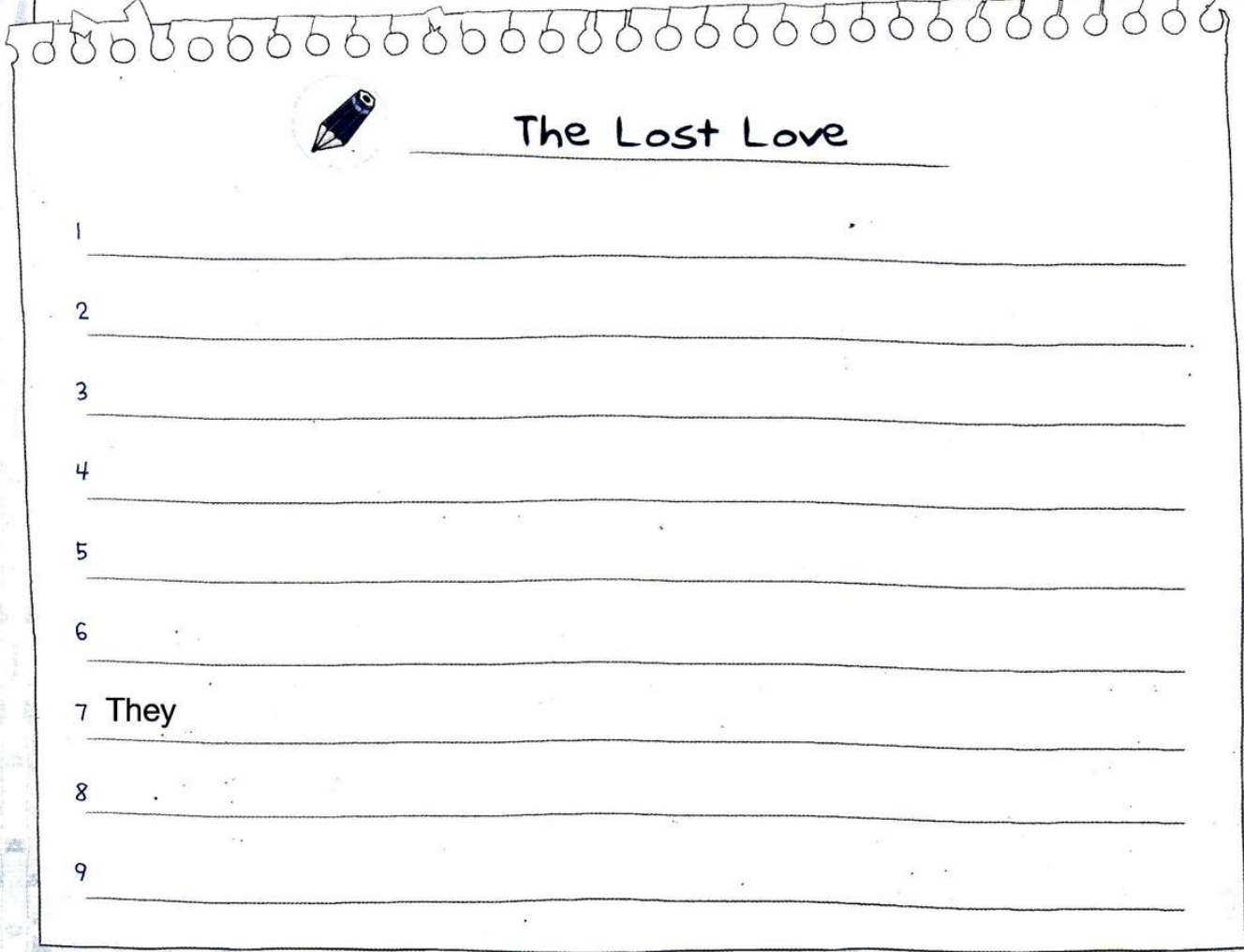
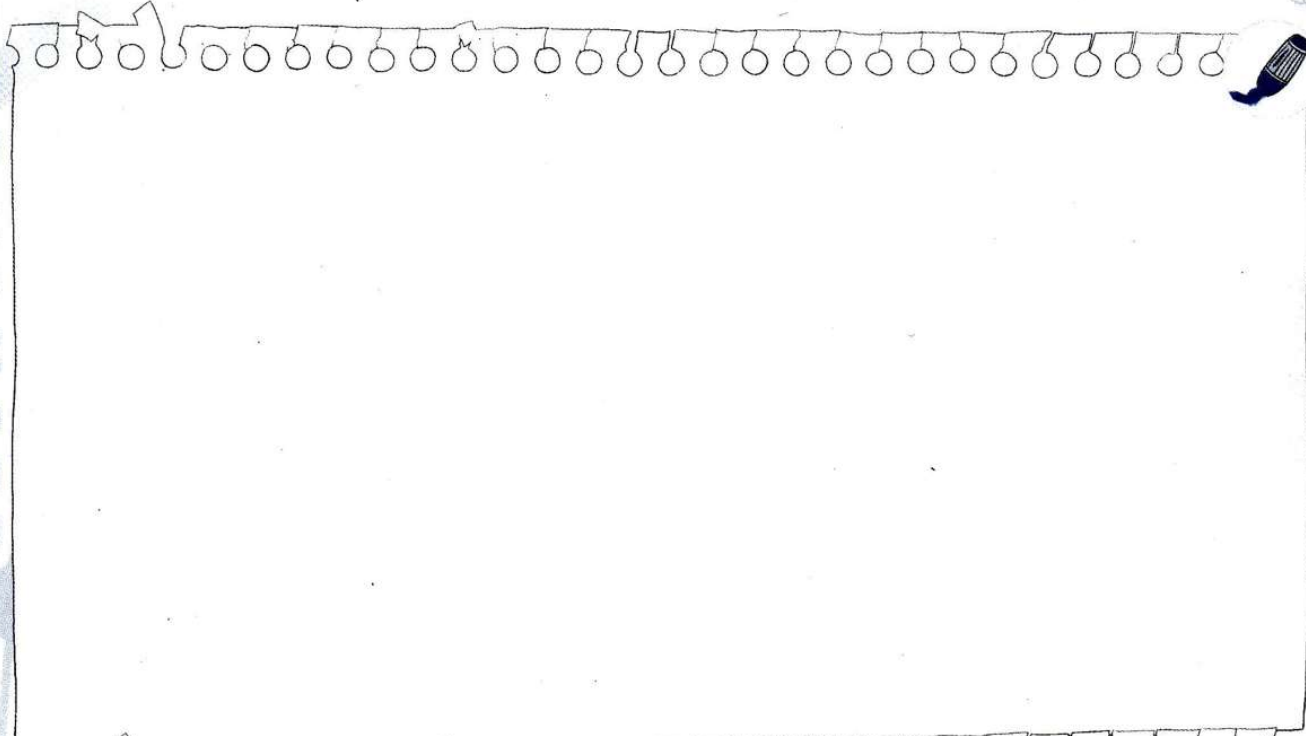

 The Lost Love

1 _____

2 _____

3 _____

4 _____

5 _____

6 _____

7 They _____

8 _____

9 _____



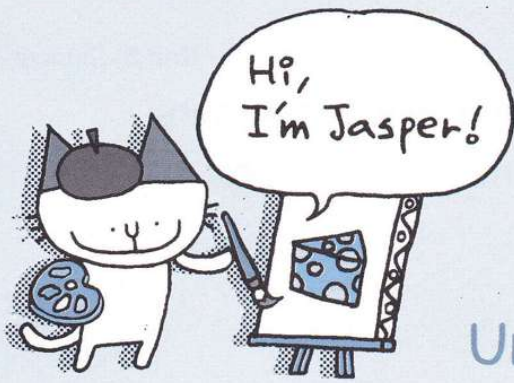

CAT TAILS

Under the Couch

Pictures by Bananabee
Story by Jason Wilburn

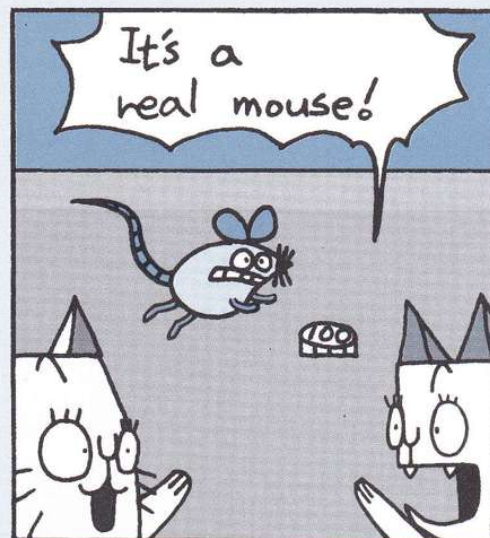
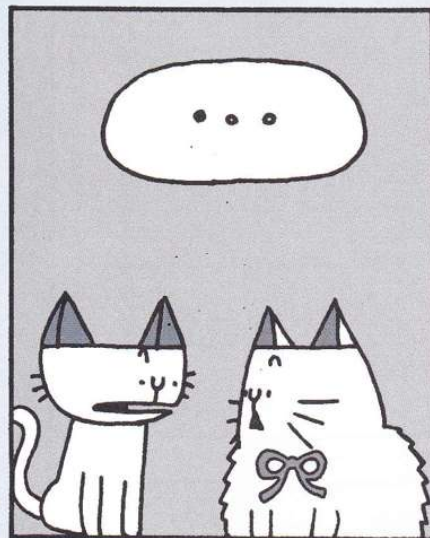
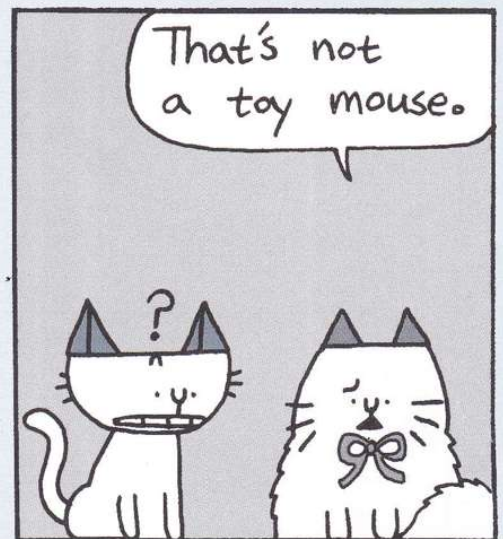
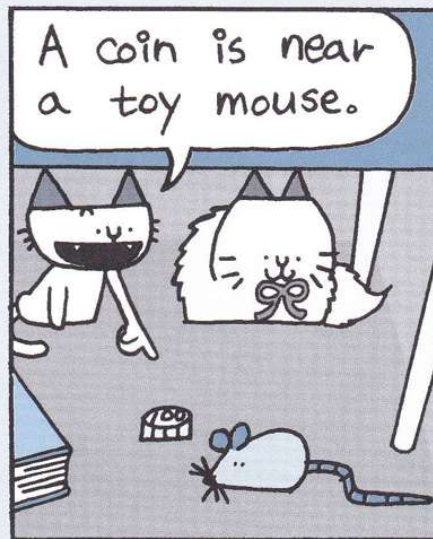
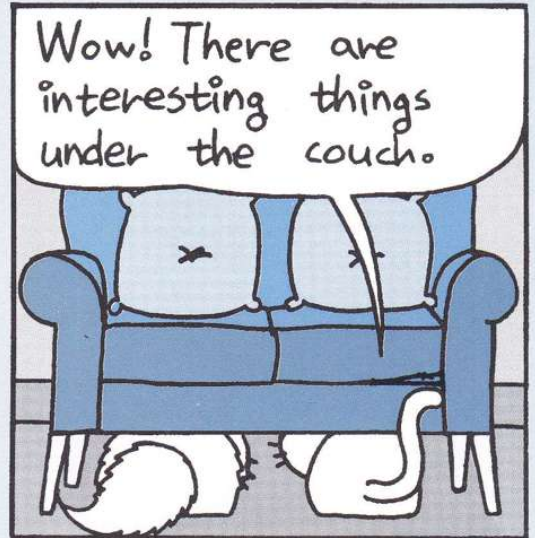

MY FIRST WRITING 2

CONTENTS

Part 2

UNIT 4 Do and About

Lesson 1	Going Out to Eat	30
Lesson 2	On My Birthday	32
Lesson 3	At the Amusement Park	34
Lesson 4	Movie Time	36

UNIT 5 Wild Animals

Lesson 1	Land Animals	38
Lesson 2	Sea Animals	40
Lesson 3	Insects	42
Lesson 4	Birds	44

UNIT 6 Famous People and Places

Lesson 1	A Famous Person	46
Lesson 2	A Famous City	48
Lesson 3	A Famous Building	50
Lesson 4	Adventures of J & J: Bigfoot	52

Going Out to Eat

Go to page 67 in your student book for help.



A. Complete the chart.

>> Write words about eating out with your family.

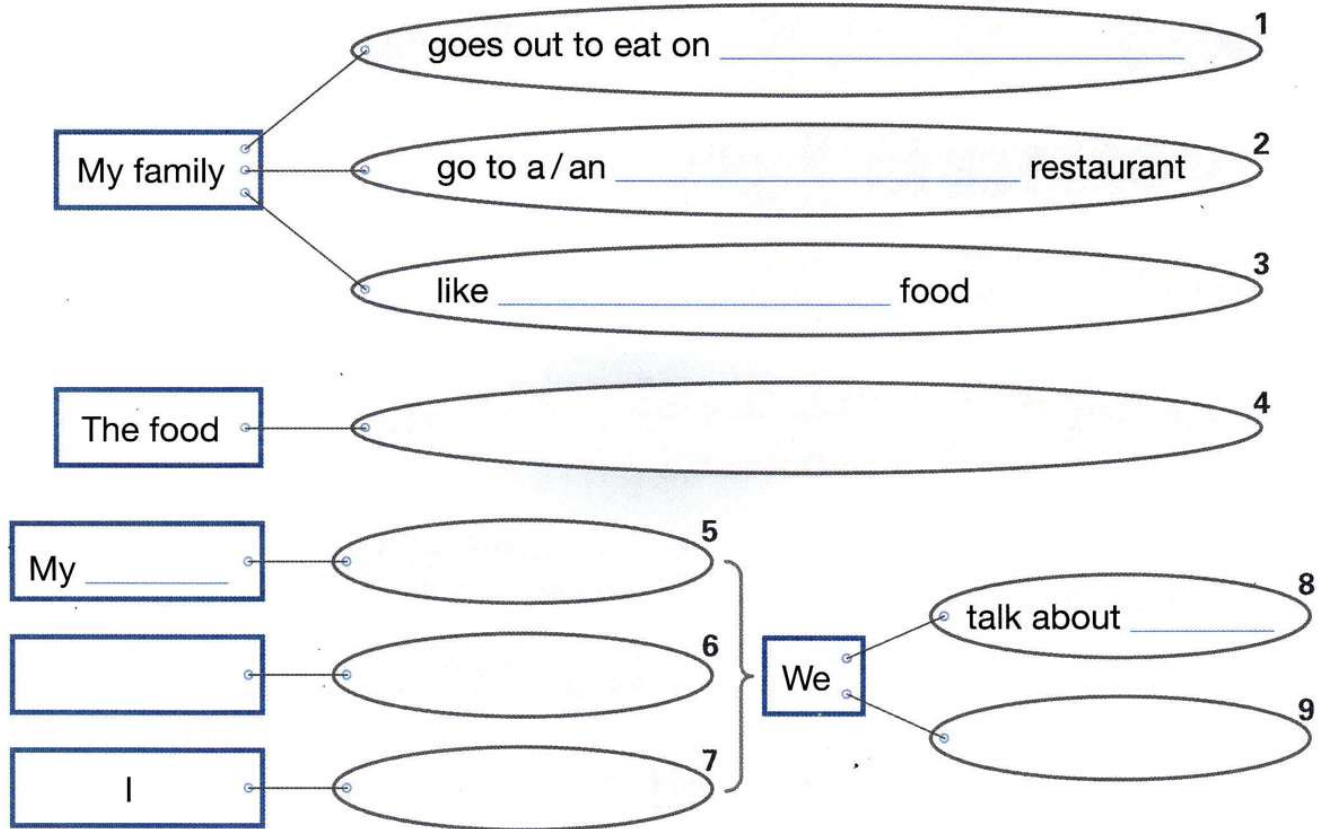

Word Bank

To Teachers: Encourage students to use their own words. When necessary, have them refer to the word bank.

Korean	bibimbop	bulgogi	galbi	Italian	spaghetti	pizza	risotto
Japanese	sashimi	sushi	udon	Mexican	burrito	nacho	taco

B. Write your story.

>> Look at the chart on the left. Draw and write your story.

A large blank area for drawing a story. On the left side, there are faint pencil sketches of a landscape with hills and a sun. On the right side, there is a faint table with four empty rectangular boxes, likely for a story structure or character list.



Title _____

1 _____

2 We _____

3 _____

4 _____

5 _____

6 _____

7 _____

8 _____

9 _____



On My Birthday

Go to page 71
in your student
book for help.



A. Complete the chart.

>> Write words about your birthday.

My birthday	in _____	1
My _____	_____	2
My _____	_____	3
My _____	_____	4
My _____	_____	5
I _____	_____	6
I _____	_____	7
My _____	_____	8
My _____ and I	_____	9

Word Bank

To Teachers: Encourage students to use their own words. When necessary, have them refer to the word bank.



make a wish



blow out candles



get many presents



sing 'Happy Birthday' song



invite friends



watch a movie



put up balloons



make a birthday cake



watch a magic show



make a banner

B. Write your story.

>> Look at the chart on the left. Draw and write your story.

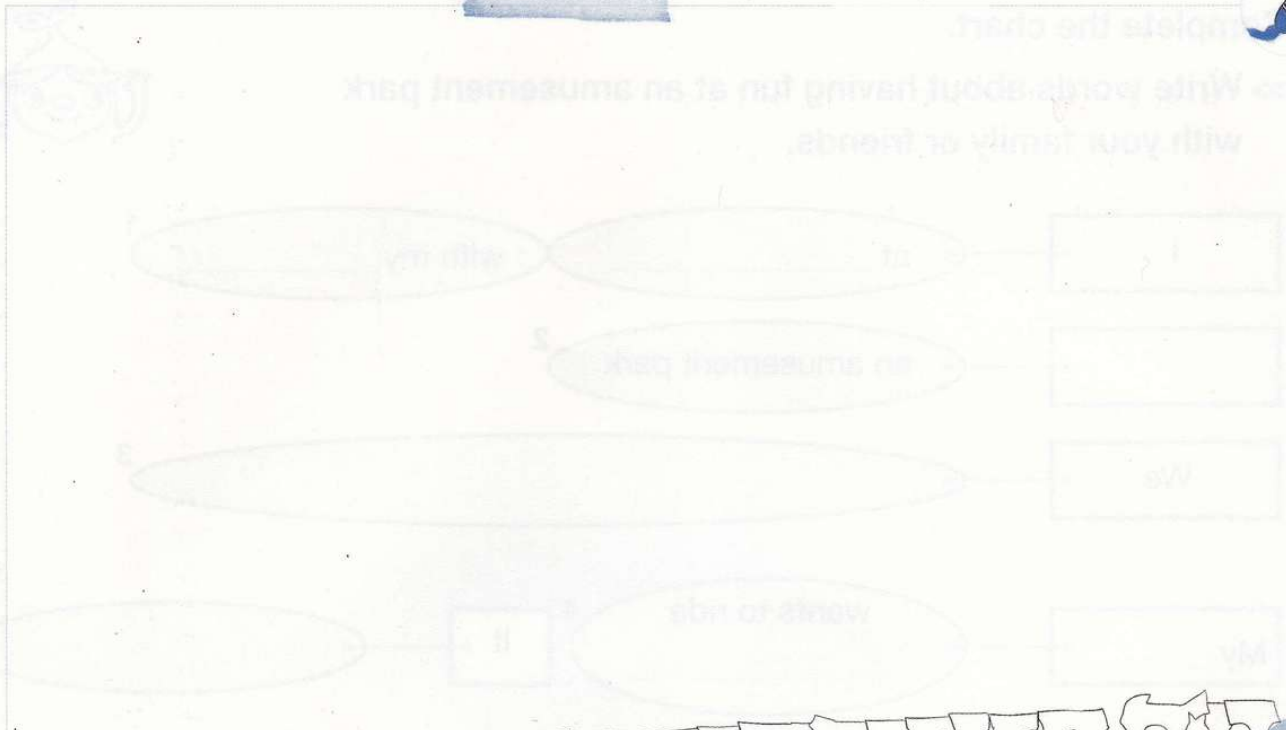

Title _____

- 1 _____
- 2 _____
- 3 _____
- 4 _____
- 5 _____
- 6 _____
- 7 _____
- 8 _____
- 9 _____



At the Amusement Park

Go to page 75
in your student
book for help.



A. Complete the chart.

>> Write words about having fun at an amusement park with your family or friends.

I	at _____	with my _____	1
	an amusement park		2
We			3
My _____	wants to ride _____	It	
	wants to ride _____	It	
I	want to ride _____	It	

Word Bank

To Teachers: Encourage students to use their own words. When necessary, have them refer to the word bank.



boring / bored



exciting / excited



scary / scared



thrilling / thrilled



roller coaster



merry-go-round



water slide



Ferris wheel



bumper car



trampoline

B. Write your story in the present or present continuous tense.

>> Look at the chart on the left. Draw and write your story.



Write words about going to the movies with your family or friends.

1	2	3	4	5	6	7	8	9



Title _____

- 1 _____
- 2 _____
- 3 _____
- 4 _____
- 5 _____
- 6 _____
- 7 _____
- 8 _____
- 9 _____



Go to page 79
in your student
book for help.



A. Complete the chart.

>> Write words about going to the movies
with your family or friends.

I _____ at _____ with my _____ 1

The theater _____ 2
 _____ 3
 _____ 4

We _____ are watching _____ 5

It _____ a _____ movie 6
 _____ about _____ 7
 _____ starts _____ 8

We _____ 9

Word Bank

To Teachers: Encourage students to use their own words. When necessary, have them refer to the word bank.



animation



fantasy



adventure



action



comedy



mystery



science fiction



screen



seat



starts at (2 o'clock)



hot dog



chocolate bar



popcorn



soda

B. Write your story in the present or present continuous tense.

>> Look at the chart on the left. Draw and write your story.

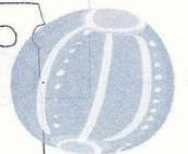

 **Title** _____

1 _____

2 _____

3 **It** _____

4 _____

5 _____

6 _____

7 _____

8 _____

9 _____



Land Animals

Go to page 85
in your student
book for help.



A. Complete the chart.

>> Write words about a land animal.
Write the animal's name in the box.

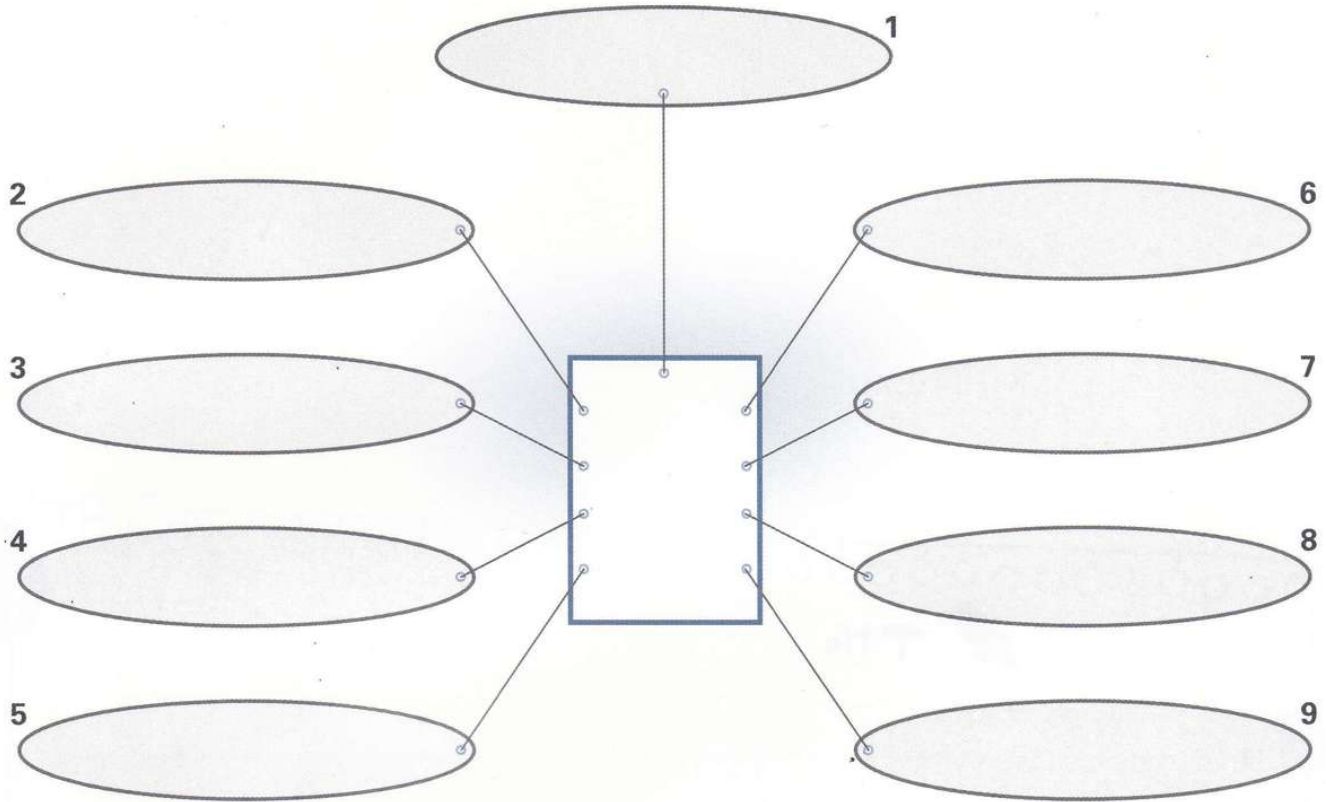

Word Bank

To Teachers: Encourage students to use their own words. When necessary, have them refer to the word bank.



Moon bears

- live in Asia
- a heavy body
- a short tail
- a moon shape / chest
- hibernate

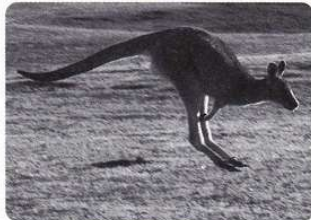

Kangaroos

- live in Australia
- a long muscular tail
- long hind legs
- short front legs
- eat grass



Lions

- live in Africa
- males - mane
- females - hunt
- eat meat
- swim very well

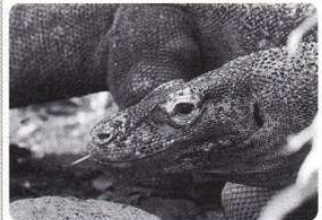

Komodo dragons

- live in Indonesia
- the biggest lizards
- a huge, muscular tail
- a flat head
- a yellow tongue

B. Write your story.

>> Look at the chart on the left. Draw and write your story.



Write the animal's name in the box.
Write words about a real animal.
Complete the chart.



Title



1

2

3

4

5

6

7

8

9



Go to page 89
 in your student
 book for help.



A. Complete the chart.

>> Write words about a sea animal.
 Write the animal's name in the box.

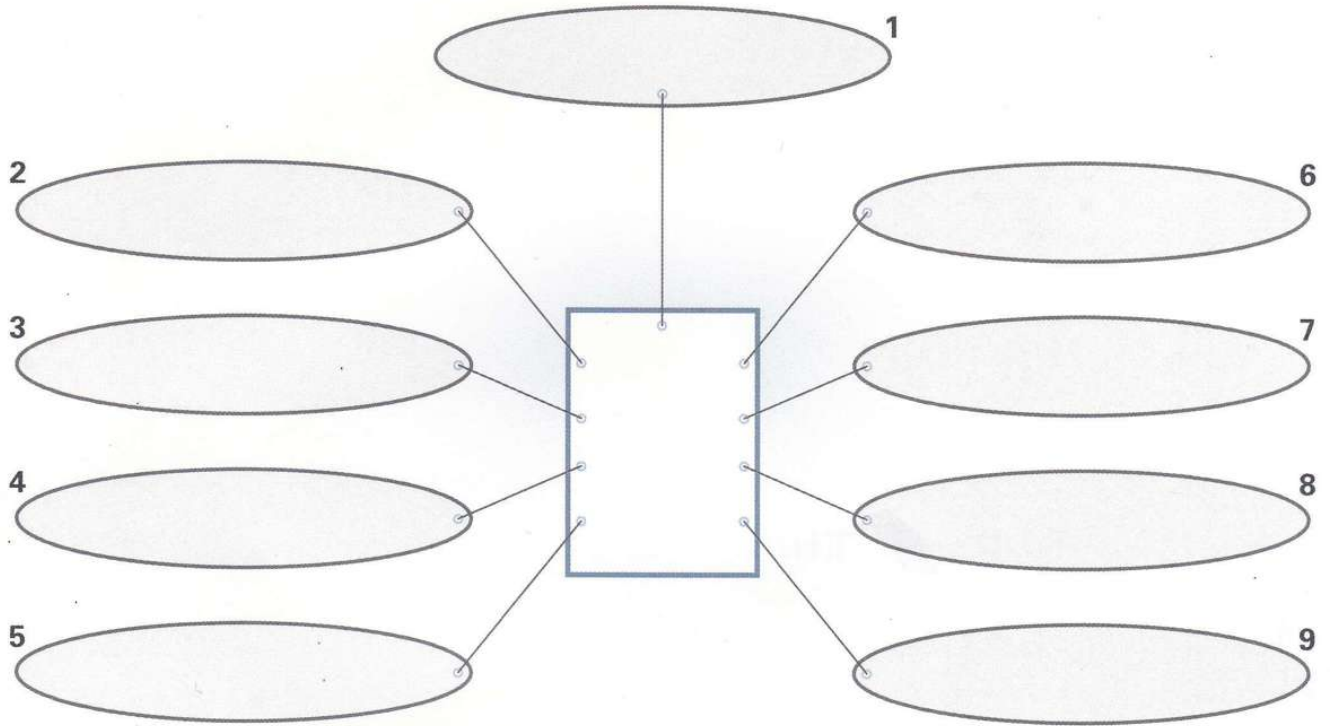

Word Bank

To Teachers: Encourage students to use their own words. When necessary, have them refer to the word bank.

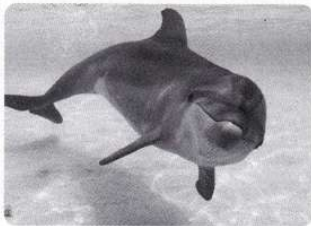

Dolphins

- a sleek body
- smooth skin
- a powerful tail
- flippers
- a blowhole / head

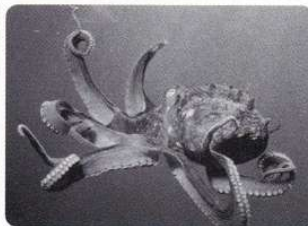

Octopuses

- a soft body
- eight arms
- a large brain
- two large eyes
- change color

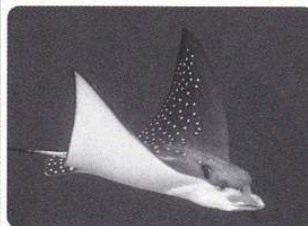

Stingrays

- a flat body
- a dangerous tail
- broad fins
- eyes / top
- a mouth / underside

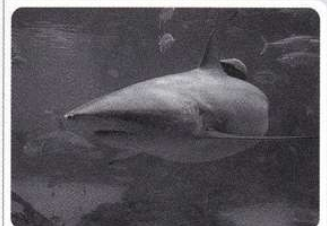

Bull sharks

- the most dangerous sharks in the world
- gray / top, white / belly
- sharp, pointy teeth
- eat meat
- smell very well

B. Write your story.

>> Look at the chart on the left. Draw and write your story.

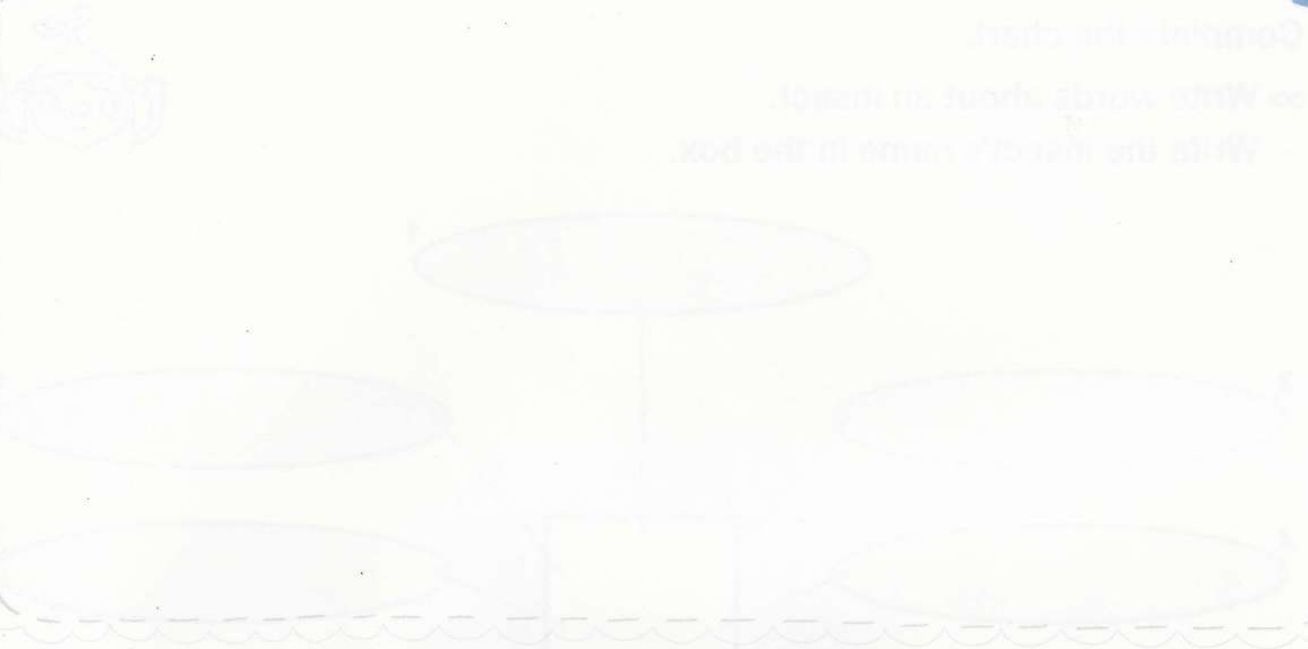

 Title _____

1 _____

2 _____

3 _____

4 _____

5 _____

6 _____

7 _____

8 _____

9 _____

Go to page 93
in your student
book for help.



A. Complete the chart.

>> Write words about an insect.
Write the insect's name in the box.

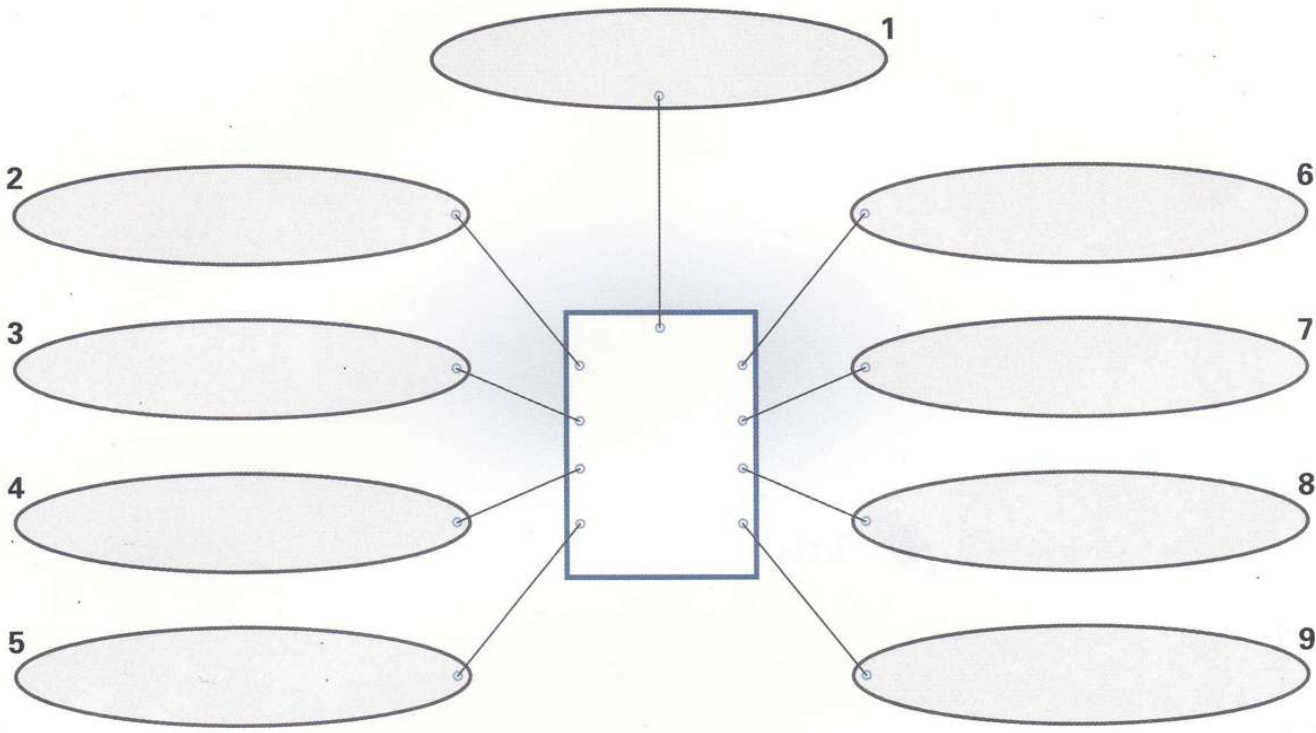

Word Bank

To Teachers: Encourage students to use their own words. When necessary, have them refer to the word bank.



Butterflies

- flying insects
- colorful wings
- eat nectar and pollen
- mouth - sucking tube
- lay eggs on plants



Ladybugs

- a type of beetles
- an oval - shaped body
- six short legs
- spots on wing covers
- females - bigger

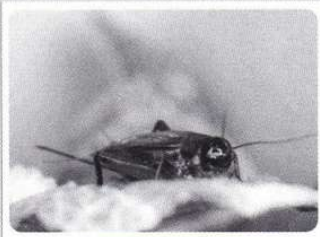

Crickets

- jumping insects
- long jumping legs
- live in the fields
- make a chirping sound
- lay eggs in the fall

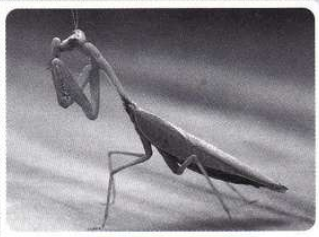

Mantises

- very long front legs
- a triangular head
- eat insects
- eat small animals
- change color
- live about a year

B. Write your story.

>> Look at the chart on the left. Draw and write your story.



Title

1

2

3

4

5

6

7

8

9



Go to page 97
in your student
book for help.



A. Complete the chart.

>> Write words about a bird. Write the bird's name in the box.

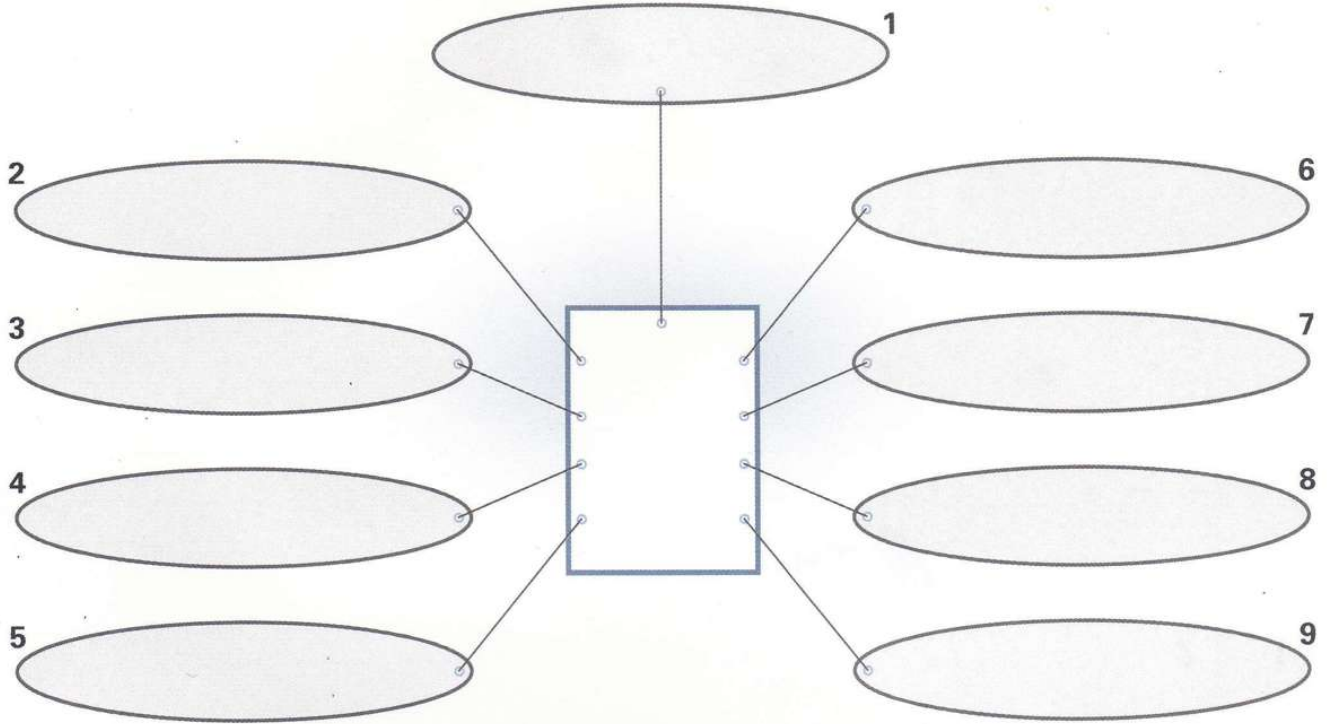

Word Bank

To Teachers: Encourage students to use their own words. When necessary, have them refer to the word bank.



Eagles

- large, powerful birds
- a hooked beak
- clawed feet
- hunt during the day
- build their nests on cliffs



Parrots

- colorful birds
- a hooked beak
- imitate human voice
- make their nests in the holes of trees



Ostriches

- the largest birds
- live in Africa
- can't fly
- can run fast
- a long neck
- lay the biggest eggs



Snowy owls

- live in the Arctic
- yellow eyes
- a black beak
- can see well
- hunt during the day
- build nests on the ground

B. Write your story.

» Look at the chart on the left. Draw and write your story.



Title

1

2

3

4

5

6

7

8

9



A Famous Person

Go to page 103
in your student
book for help.



A. Complete the chart.

>> Write words about a famous person.

Write his or her name in the box.

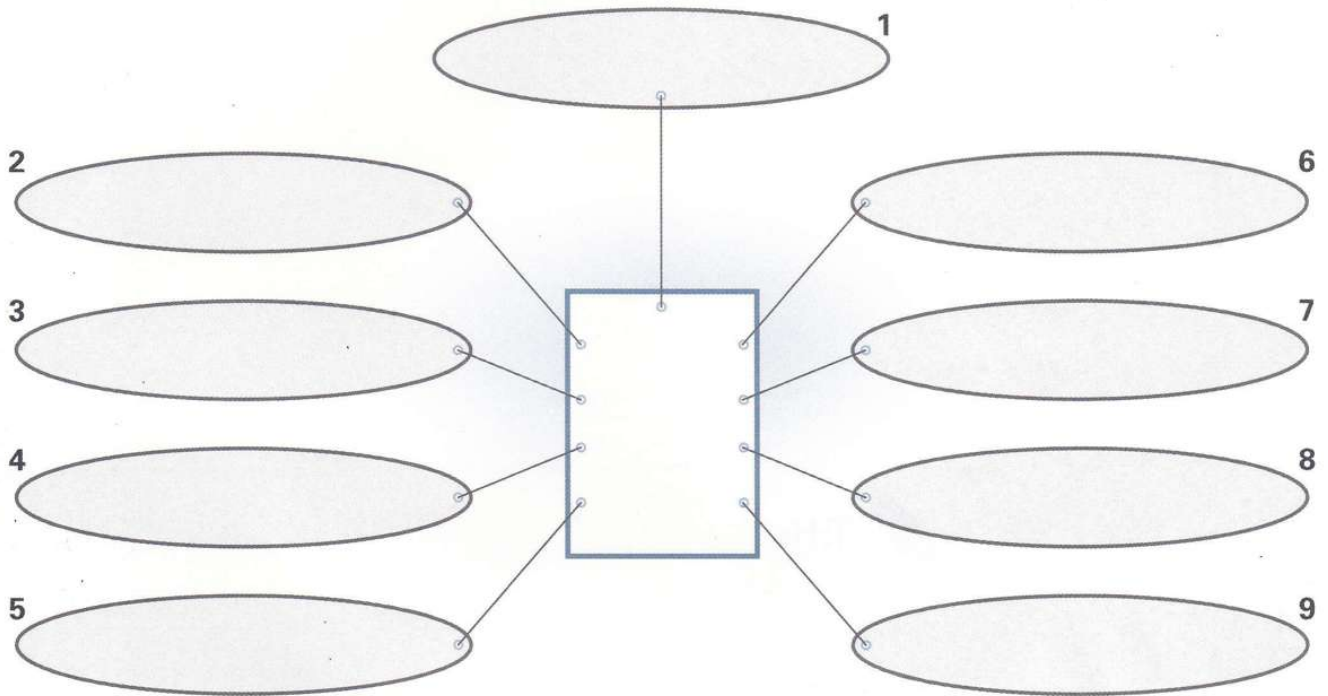

Word Bank

To Teachers: Encourage students to use their own words. When necessary, have them refer to the word bank.



Bill Gates

- American
- born in 1955
- businessman
- Microsoft
- rich



Yelena Isinbayeva

- Russian
- born in 1982
- pole jumper
- Olympic gold medalist
- world record



Ban Ki-moon

- Korean
- born in 1944
- 8th Secretary-General of UN
- speaks 5 languages
- two daughters and a son



Jackie Chan

- Chinese
- born in Hong Kong
- born in 1954
- actor
- action movies

B. Write your story.

>> Look at the chart on the left. Draw and write your story.



Write words about a famous city.
Write the city's name in the first box.

 Title

- 1
- 2
- 3
- 4
- 5
- 6
- 7
- 8
- 9

A Famous City

Go to page 107
in your student
book for help.



A. Complete the chart.

>> Write words about a famous city.

Write the city's name in the first box.

1				2
				4
				5
				6
				7
				8
				9

There

3

Word Bank

To Teachers: Encourage students to use their own words. When necessary, have them refer to the word bank.

Beijing
in China



- The Great Wall:
6,700 km long



- The Forbidden City:
an old palace

New York
in the U.S.



- The Statue of Liberty:
a gift from France



- Central Park:
a large city park

Rome
in Italy



- Coliseum:
an old amphitheater



- The Vatican City:
The Pope

Seoul
in South Korea



- Gyeongbokgung:
first built in 1394



- Namdaemun Market:
a busy place

B. Write your story.

>> Look at the chart on the left. Draw and write your story.



 Title

1

2

3

4

5

6

7

8

9

A Famous Building

Go to page 111
 in your student
 book for help.



A. Complete the chart.

>> Write words about a famous building.
 Write the building's name in the box.

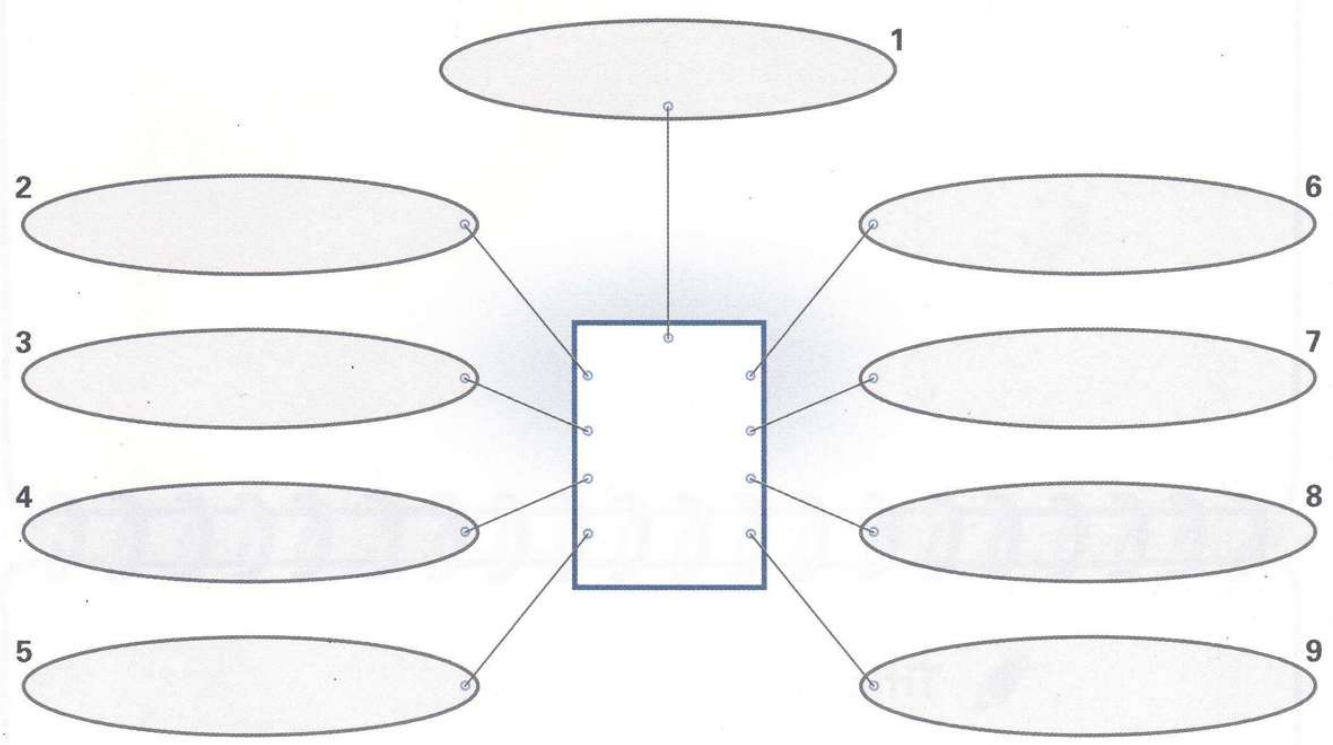

Word Bank

To Teachers: Encourage students to use their own words. When necessary, have them refer to the word bank.



Empire State Building

- New York, U.S.
- built in 1931
- 102 floors
- 443 m tall
- tallest building in New York



The Great Pyramid of Giza

- Egypt
- 4,500 years old
- about 140 m tall
- tomb of King Khufu
- largest stone building in the world



The Tower of Pisa

- Pisa, Italy
- a bell tower
- 56 m tall
- leans to the southwest
- 296 or 294 steps



The Great Wall

- Beijing, China
- 6,700 km long
- 2,000 years old
- a giant dragon
- many watch towers

B. Write your story.

>> Look at the chart on the left. Draw and write your story.



A large rectangular area for drawing, enclosed in a thick black border. The area is mostly blank, with some faint, mirrored text from the reverse side of the page visible.



Title

1

2 It

3

4

5

6

7

8

9

Adventures of J & J

- Bigfoot -

A. Choose and complete the chart.

	go	look for	take (x2)
There	a strange animal	in the woods	1
Its name	Bigfoot		2
Bigfoot	a famous monster		3
	big, smelly and scary		4
5	_____ their mom's camera	Janice and Jacob	_____ to the bushes
6	_____ Bigfoot		_____ a picture
It	not Bigfoot		9



B. Write the summary of the comic. Use a Be-verb when necessary.

>> Look at the chart on the left. Draw and write the summary.

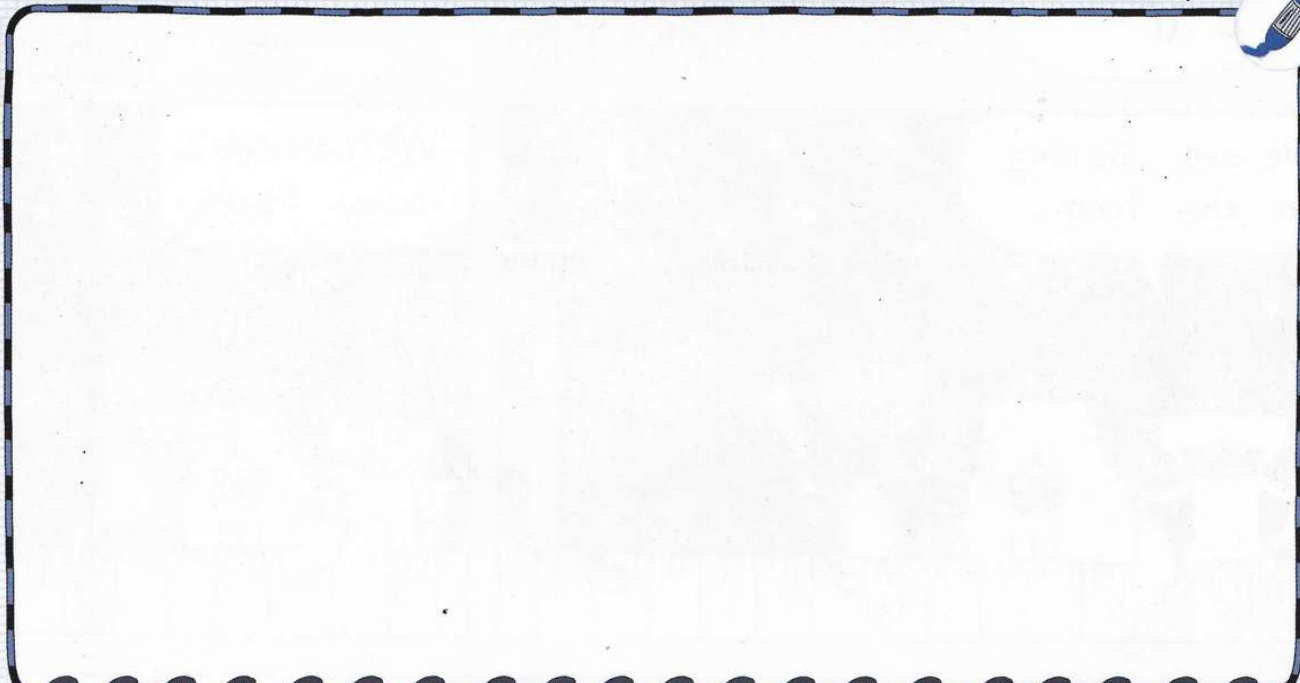

Big Foot

1

2

3

4 It

5

6 They

7

8

9 But,

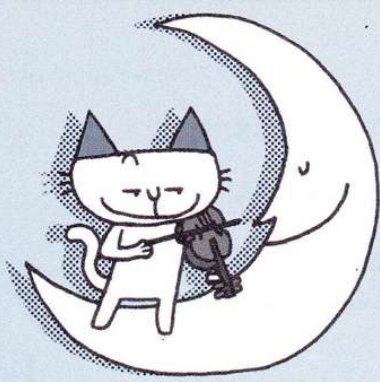

CAT TAILS

Night Sky

Pictures by Bananabee
Story by Jason Wilburn

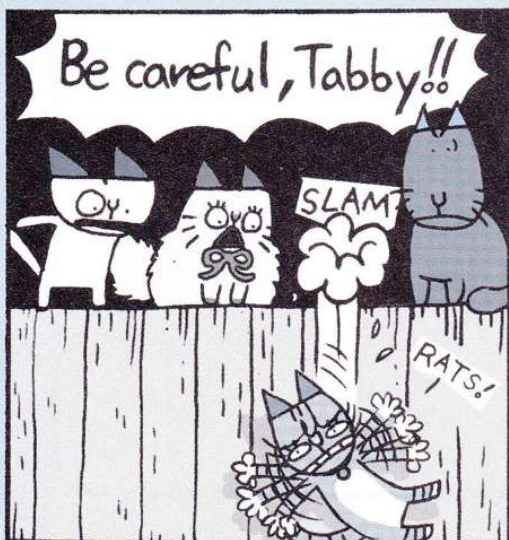
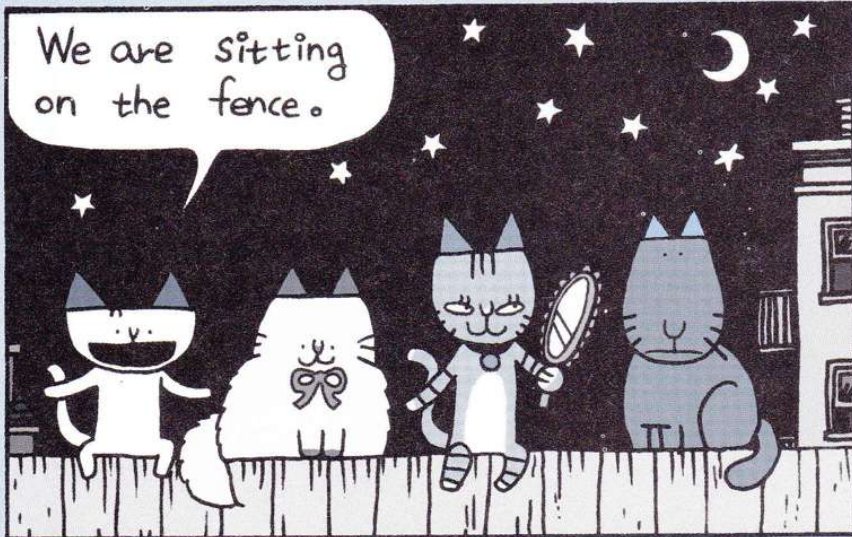

MY FIRST WRITING

is a fun and easy writing series for young EFL beginners. It is designed to help students develop sentence building skills from the start. Students will begin to write sentences within a context of fun topics they can easily relate to. With the help of the characters in the series, students will learn to write sentences step by step. The interesting characters are used to grasp the students' attention from beginning to end and guide them through. Throughout the series, students will expand their vocabulary in meaningful linguistic collocations. Vocabulary is introduced in fun activities using illustrations and real photos. The series will develop and enhance students' sentence building skills in a fun and engaging way leading them to paragraph writing.

Key Features

- American English
- An Interesting Family of Characters
- Familiar Topics Children can Relate to and Write about
- Activities for Developing Sentence Building Skills
- Vocabulary Arranged in Meaningful Linguistic Collocations
- A Systematic Writing Process using Graphic Organizers
- Summary Writing Practice through Fun Comics
- Various Writing Projects

Components

- Student Book 1 2 3
- Workbook 1 2 3
- Teacher's Manual 1 2 3

